

# Electronic Turbine Meter TERZ 94



**RMG Meßtechnik GmbH**

P.O.Box 280 · 35502 Butzbach (Germany)  
Tel.: +49 (0)6033 897-0 · Fax: +49 (0)6033 897-130  
E-mail: [messtechnik@rmg.de](mailto:messtechnik@rmg.de) · Internet: <http://www.rmg.de>



Publication No. 3.174-E

Serving the Gas Industry  
- WORLDWIDE

## 1. Method of operation

The TERZ 94 electronic turbine meter is a flow meter which directly measures the flow rate of gases at measurement conditions. The flow rate measured and the volume are displayed on an electronic totalizer.

The operating principle of the meter is based on velocity measurement using a turbine wheel. The gas flow passes the ring-shaped inlet section of the flow straightener and reaches the coaxially mounted turbine wheel, whose speed is proportional to the mean velocity of the gas flow within the scope of the measuring range.

The speed of the turbine wheel is recorded inductively using non-contact measurement by a pulse-wire sensor and a permanent magnet. Due to the fact that the signal frequency is directly picked up at the turbine wheel, the meter is also suitable for control applications.

## 2. Construction

The electronic turbine meters form a series of uniform construction. Each meter consists of four structural units (see drawing). An aerodynamic flow straightener fitted into the meter case constricts the effective cross section of the pipe to form a ring-shaped cross-sectional area and substantially eliminates turbulence. This increases the velocity of the flowing gas. The shaft mounted with ball bearings carries the turbine wheel on the one side and a permanent magnet rotating before the sensor on the other. The duct of the sensor sleeve towards the unpressurized section of the electronic totalizer is sealed off by a pressure-tight O-ring. By means of the clamping screw, the electronic totalizer can be fixed in the most favourable position for taking readings.

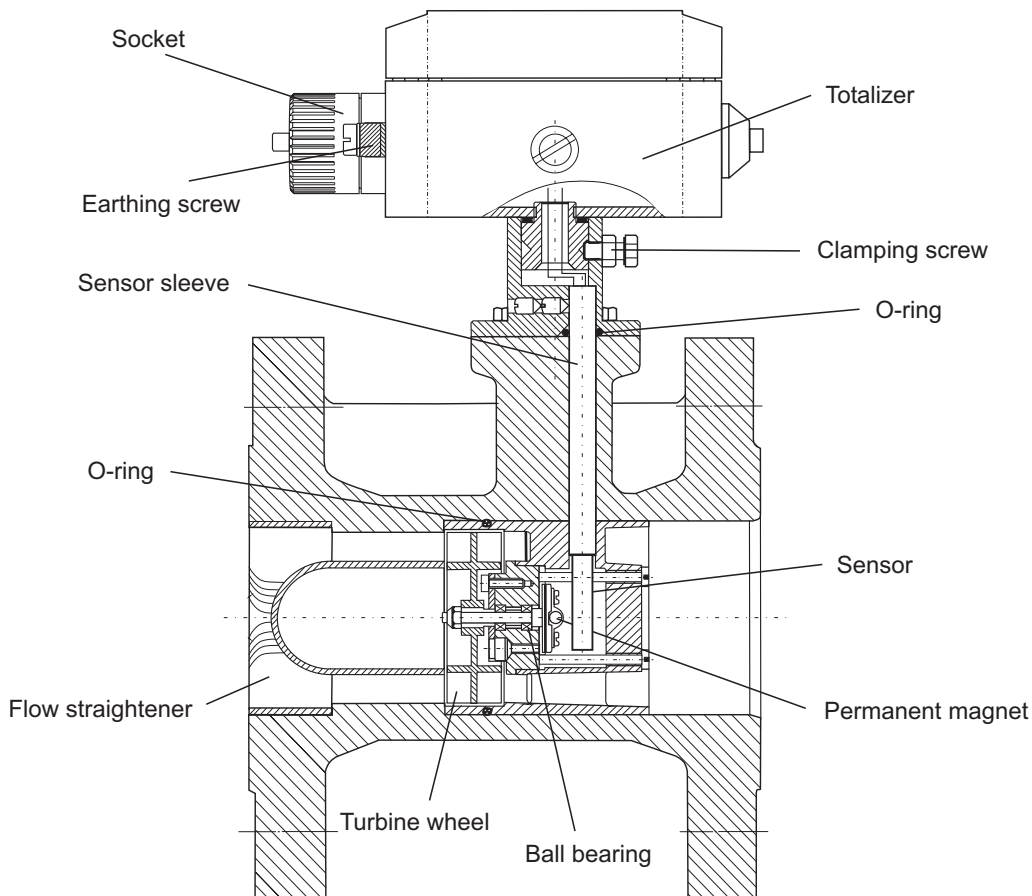

## 3. Types of gases

The TERZ 94 standard design is suitable for all gases complying with DVGW Code of Practice G260. The materials used are appropriate for gases and fuel gases, such as natural gas, refinery gas, liquid gases and their mixtures, nitrogen, CO<sub>2</sub> (dry), air and all

inert gases.

For corrosive and chemical gases, there are special designs available with PTFE lining, special material, special lubrication, etc.

## 4. Characteristics

- **Electronic totalizers**  
(Main totalizer, additional start-stop or resettable totalizer for external totalizer disablement in order to suppress the slow-down effect of the turbine wheel after the gas flow has stopped.)
- **2 sensor inputs (option)**  
with mutual monitoring
- **Battery mode (version without a current board)**  
Service life of the battery is a minimum of 6 years.
- **4-20 mA current output (transmitter)**  
(only with the version with a current board)
- **Low-torque metering system with long-term stability**  
(apart from the turbine wheel, there are no mechanically actuated parts)
- **LF and HF pulse outputs**  
(The pulse value of the LF pulse output is user-programmable.)

- **Intrinsically safe circuit, approved for zone 1**
- **Degree of protection: IP 65**
- **Flow display**
- **Storage of maximum values (Qm)**
- **Temperature ranges (standard)**  
Fluid temperature range: -10°C to +50°C  
Ambient temperature range: -20°C to +60°C
- **Compact construction with a rotatable meter head**
- **Option for use as a remote totalizer**
- **Alarm output (option)**

## 5. Approvals

### II 2 G EEx ib[ia] II C T4 / T3

as per certificate of conformity No.: TÜV 02 ATEX 1970

### DVGW product ID No.: CE-0085BN0292

(Testing in accordance with the Directive for Pressure Equipment 97/23/EG)

## 6. Electronic totalizer

Possible connections of the electronic totalizer:

HF pulse output (high frequency) direct signal frequency	LF pulse output (low frequency) decade-scaled	Switch input for stopping the totalizer	4-20 mA current output Version with a current board (option)
Transistor, open collector	Transistor, open collector	Switching contact (potential-free)	Current loop connection (4-20 mA, 2-wire technology)
$U_{max} = 28 \text{ V (Ex)}$ $30 \text{ V (non Ex)}$	$U_{max} = 28 \text{ V (Ex)}$ $30 \text{ V (non Ex)}$	Totalizer stop: closed contact	$U_{max} = 28 \text{ V}$
$U_{min} = 4.0 \text{ V}$	$U_{min} = 4.0 \text{ V}$		$U_{min} = 12 \text{ V}$
$I_{max} = 30 \text{ mA}$	$I_{max} = 30 \text{ mA}$		$I_{max} = 23 \text{ mA}$
$T_{pulse} = 1 \text{ ms}$	$T_{pulse} = 125 \text{ or } 250 \text{ ms}$		$I_{min} = 3.5 \text{ mA}$
$f_{max} = 250 \text{ Hz}$ For frequency values, see table below Overview section	$f_{max} = 4 \text{ Hz}$ For possible setting values, see table below Overview section		Error less than 1% of the final value. External power supply unit required.

### Connection of the current output (example for installation in areas subject to explosion hazards)

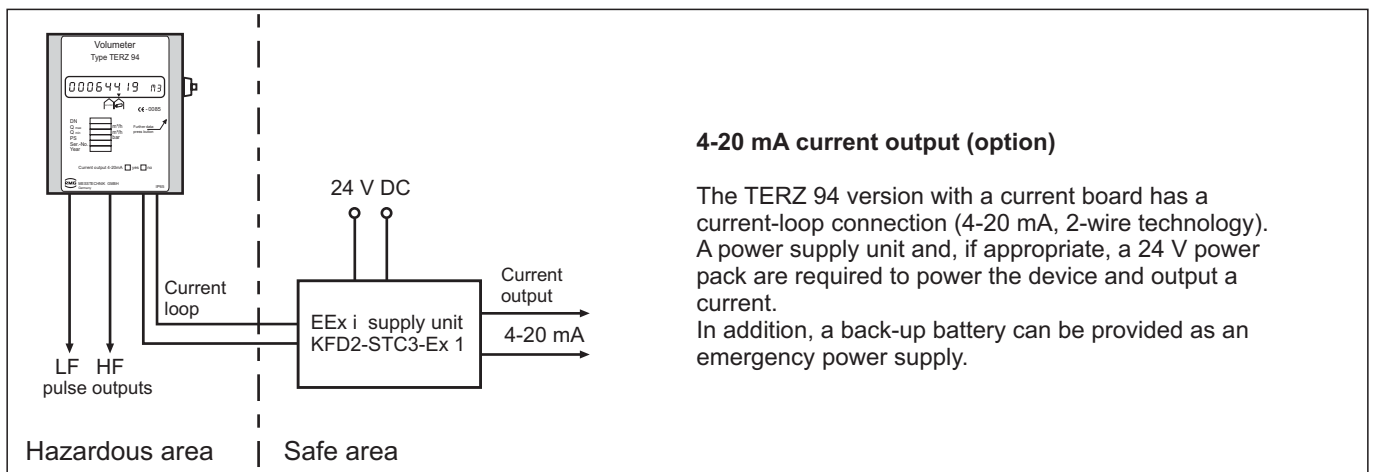



## 11. Types of construction and dimensions

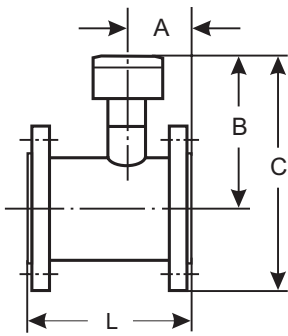

Flanged-end design (F)

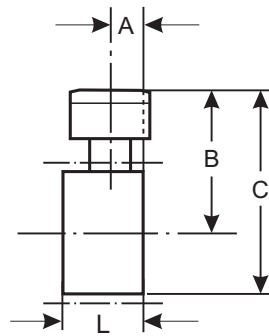

Sandwich design (S)  
(Adaptor-flange mounting)

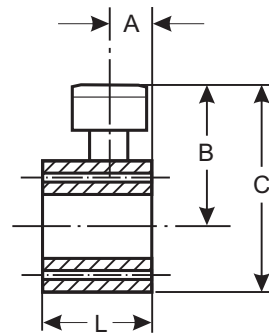

Monoflange design (M)

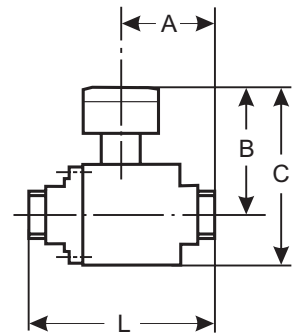

Threaded-end design (G)  
(only aluminium cases)

Case design	Weights and measures						Pressure rating				
	Nominal size mm	L mm	A mm	B mm	C mm	Weight kg <sup>1)</sup>	PN 10 PN 16	PN 25 ANSI 150	PN 40	ANSI 300	PN 64 PN 100 ANSI 600
<b>G</b> Threads	25 <sup>2)</sup>	185	80	145	195	4	Alu				
	40 <sup>3)</sup>	140	80	145	195	4	Alu				
<b>F</b> Flanges	50	150	60	180	265	10	•	•	•	•	
	80	120	35	215	315	14	•	•	•		
	100	150	50	225	345	25	•	•	•		
	150	175	70	255	410	40	•	•	•		
	200	200	70	280	470	60	•	•	•		
	250	300	135	320	540	70	•	•			
	300	300	95	325	580	100	•	•			
		450	200	325	610	200			•	•	•
	400	400	145	335	650	180	•	•			
		600	345	335	680	400			•	•	•
500	400	110	385	760	300	•	•				
	750	260	385	810	650			•	•	•	
600	600	130	440	870	400	•	•				
	900	280	440	920	850			•			
<b>M</b> Mono-flanges	50	80	60	175	255	15					•
	80	120	35	200	300	35				•	•
	100	150	50	225	355	50				•	•
	150	175	70	270	445	100				•	•
	200	200	70	305	510	130				•	•
250	250	85	345	590	200			•	•	•	
<b>S</b> Sandwich	50	80	30	145	195	12 <sup>4)</sup>	Alu	•			
	80	120	30	200	280	20	•	•			
	100	150	50	220	330	30	•	•			
	150	175	70	250	400	50	•	•			
	200	200	70	280	450	70	•	•			
250	250	85	315	530	110	•	•				

1) The weights are approximate values. Devices with a lower pressure rating can have a lower weight.

2) External thread R 1½"; with coupling kit: internal thread Rp1 ISO 7-1, overall length 243 mm

3) External thread R 2¼"; with coupling kit: internal thread Rp1½ ISO 7-1, overall length 206 mm

4) 4 kg for PN 10 and PN 16 (aluminium case)

Special designs on request.

# Electronic Turbine Meter TERZ 94

## 12. Options for installing the electronic totalizer

By installing the electronic totalizer in different ways, optimum readings can be taken in any position. If no

special type of installation is specified, the totalizer is to be installed in accordance with the figure below.

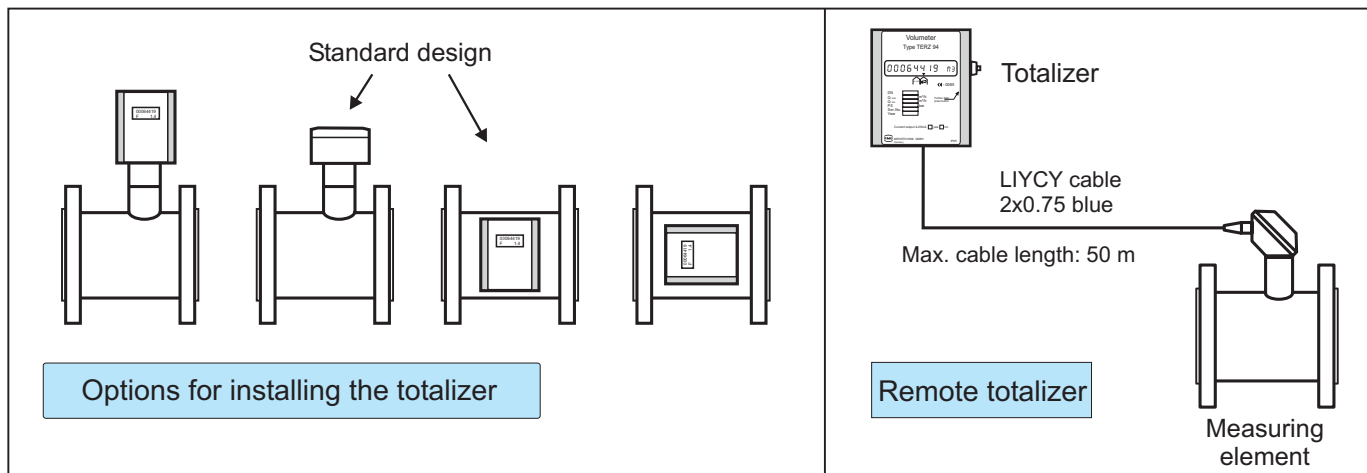

## 13. Device variants

Our product range also includes the following device types which are based on the electronics of the TERZ 94:

### TRZ03-TE/TEL electronic turbine meter

1 or 2 channels, measuring element as with the TERZ 94, but incorporated into the housing of the TRZ 03 or TRZ 03-L. The 2-channel version has been approved for custody transfer measurement (PTB 7.211/02.13).

### EC 21 temperature corrector

1 or 2 channels, directly installed on a turbine meter or volumeter with an electronic measuring element (Wiegand sensors) or 1-channel version installed together with a (separate) mechanical totalizer (volume pulses from reed contact). With a Vm totalizer and a corrector function with measured temperature values and a fixed pressure value.

### EC 24 volume corrector

1 or 2 channels as with the EC 21, directly installed on a turbine meter or volumeter with electronic measuring element (Wiegand sensors) or 1-channel version installed together with a (separate) mechanical totalizer (volume pulses from reed contact). The EC 24 includes a Vm totalizer and a corrector function with measured pressure and temperature values. The pressure transmitter is

incorporated into the housing.

All variants receiving signals from Wiegand sensors, i.e. all variants which are directly installed on the meter, have LF and HF pulse outputs and are available as devices with a current output.

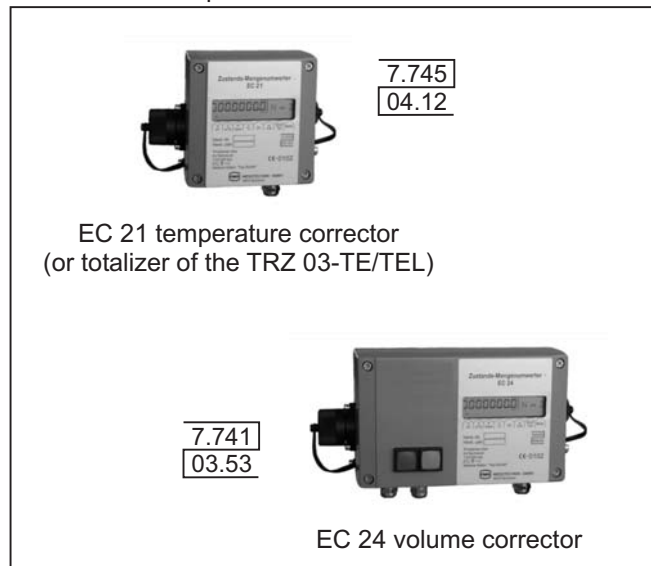

**RMG Meßtechnik GmbH**



Publication No. 3.174-E

P.O.Box 280 · 35502 Butzbach (Germany)  
Tel.: +49 (0)6033 897-0 · Fax: +49 (0)6033 897-130  
E-mail: messtechnik@rmg.de · Internet: <http://www.rmg.de>

Status: 05/2005  
Subject to technical modification  
without prior notice.