

# Superior Calorific Value, Standard Density and Wobbe Index Measuring Device **EMC 500**

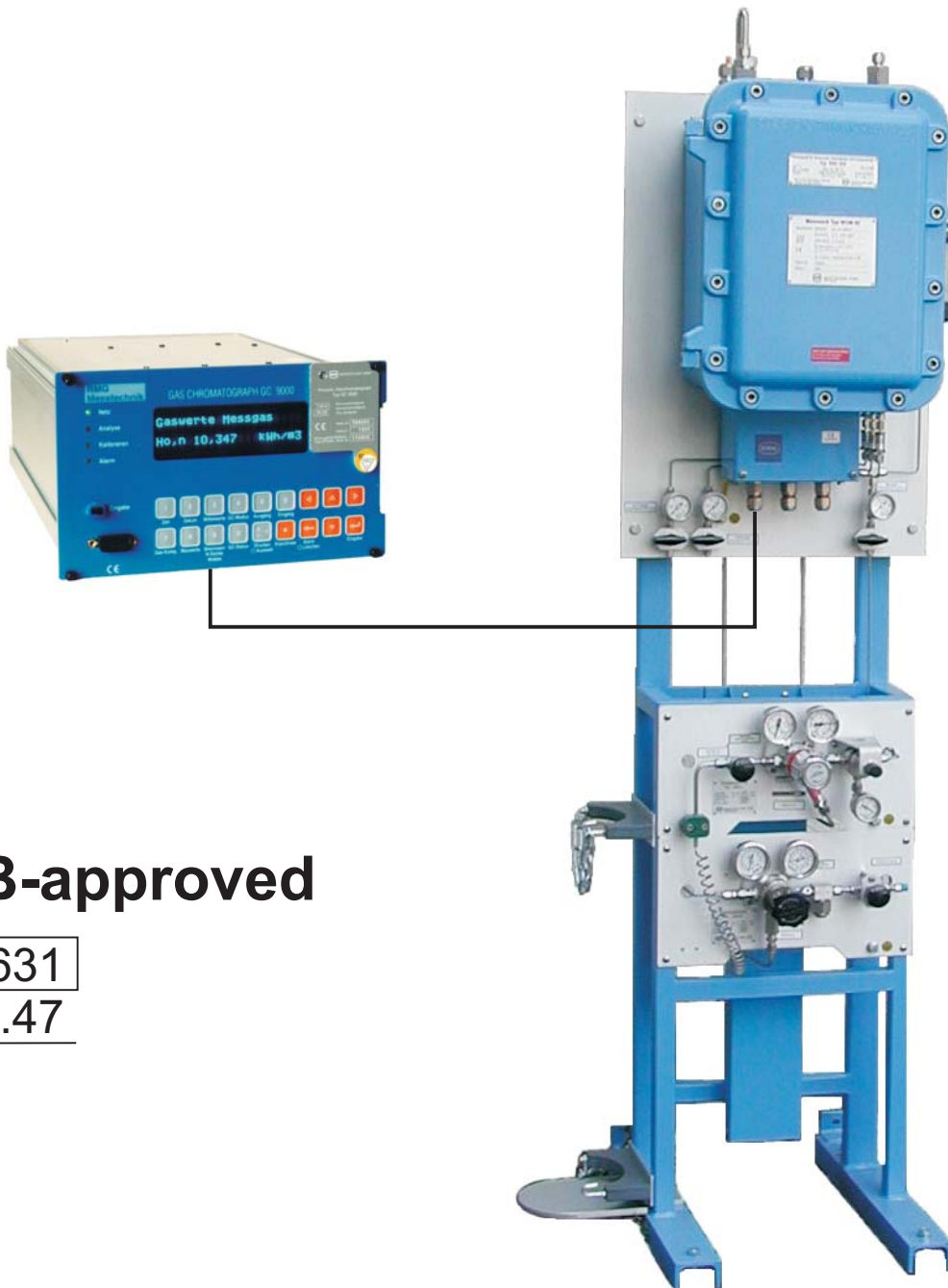

**PTB-approved**

7.631  
03.47

**RMG Messtechnik GmbH**

P.O.Box 280 · D-35502 Butzbach (Germany)  
Tel.: +49 (0)6033 897-0 · Fax: +49 (0)6033 897-130  
E-mail: [messtechnik@rmg.de](mailto:messtechnik@rmg.de) · Internet: <http://www.rmg.de>



Publication No. 7.121-E

Serving the Gas Industry  
- WORLDWIDE

## Fields of application

The measuring element of the EMC 500 continuously determines the **superior and inferior calorific values, standard density and Wobbe index** of natural gas. The EMC 500 as a calorific value measuring device is particularly suitable for local gas systems with minor variations in the superior calorific value, and in measuring stations with lower flow rates, e.g. at individual industrial gas consumers. Apart from measurements for billing purposes, the device can also be used in applications where two gases are mixed, binary mixtures are analyzed or gas burners are controlled by means of the Wobbe index.

The EMC 500 is a low-cost alternative to the process gas chromatograph and provides the necessary quantities for the determination of the energy content and K coefficient of natural gas. The carbon dioxide content required for the calculation of the K coefficient is also measured.

The measuring device EMC 500 has been approved for custody transfer measurement of the superior calorific value, standard density and carbon dioxide content for gases of the second gas family (natural gases), described in the DVGW guideline G 260.

## Method of operation

At the heart of the EMC 500 lie two thermal sensors depending on the type of gas which are used to measure the heat capacity, thermal conductivity and viscosity of the gas. Since these quantities represent a function of the superior calorific value over a wide range, it is possible to calculate the superior and inferior calorific values from these measured values (correlative method of measurement). The standard density is determined using the pressure drop measured by a flow resistor, the carbon dioxide content of the gas is measured by an infrared sensor.

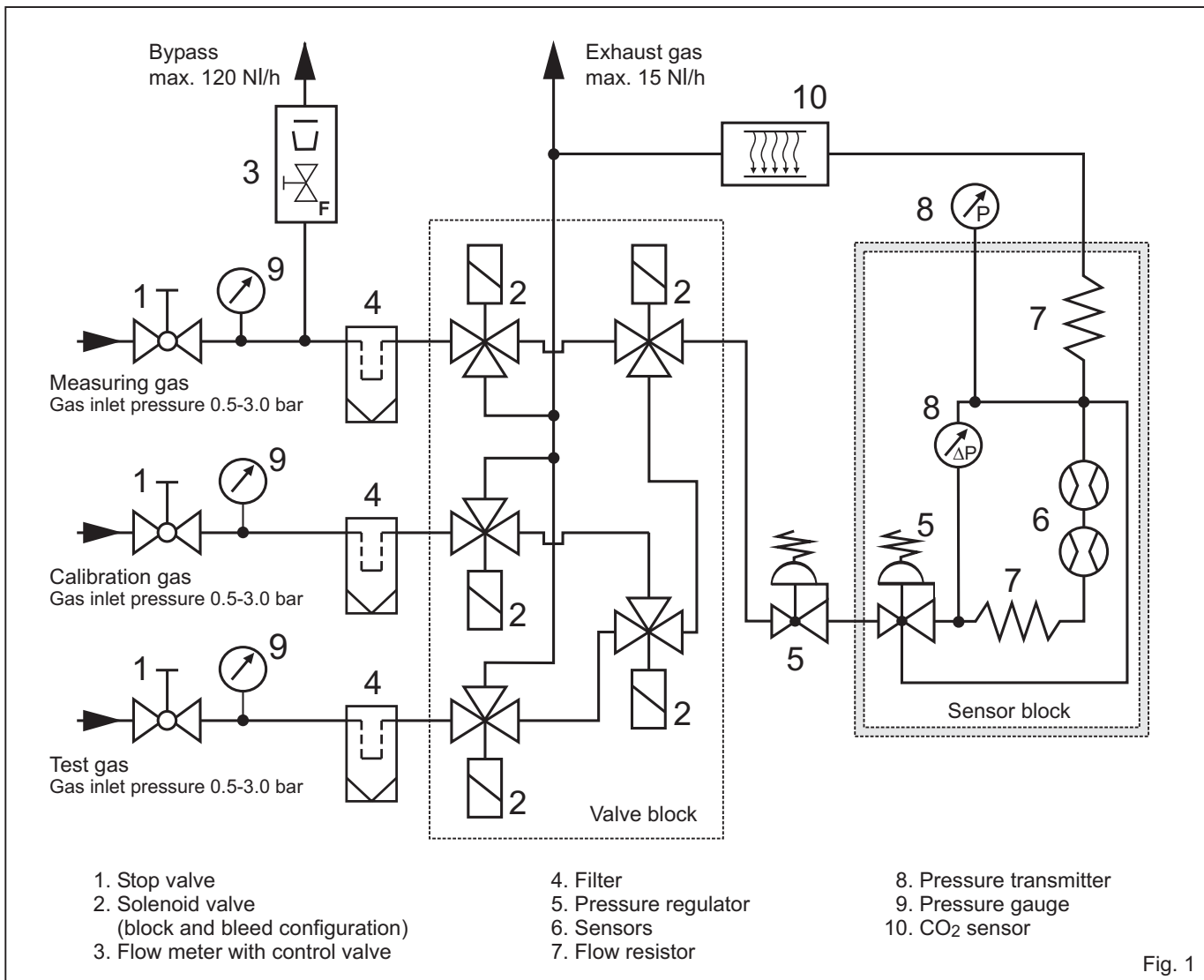

Fig. 1

## Features

- **Combustion-free measuring method:** No undesired heat is produced and no air must be supplied.
- **No influence of the environment:** Atmospheric pressure and ambient temperature variations do not affect measurements. No air conditioning is required at the place of installation.
- **Low on maintenance.**
- **No carrier or auxiliary gas required.**
- **Simple and straightforward operation.**
- **Short response times.**
- **Automatic recalibration.**
- **Low operating costs.**
- **Ex and Non Ex designs.**
- **Calibration with methane.**
- **Air admixture up to 20% is possible** with the version EMC 500-L
- **Test gas inlet**
- **Calculation of the methane number (option)**

## Construction

The EMC 500 calorific value measuring device consists of the WOM 02 C measuring element with the thermal sensors and pressure regulators, and the analytical computer. The measuring element is fixed to a mounting plate and is available either as Non-Ex design or Ex design with an explosion-proof enclosure. The analytical computer is installed in a control cabinet in the electrical control room.

Temperature control and thermal insulation of the measuring element prevent the ambient temperature affecting the measuring performance. Solenoid valves are used to switch between the measuring gas and the calibration gas from a permanently connected gas cylinder, calibration cycles are performed automatically.

Part of the measuring gas can be discharged through a bypass without passing the measuring element. This increases the flow in the supply pipe, and all the time current measuring gas is measured.

## Air admixture

With the variant **EMC 500-L** also gas with an admixture of up to 20% of air can be measured. In this case superior calorific value and CO<sub>2</sub> content may be used for fiscal metering. With agreement of the local authority the measured standard density may be used to calculate the compressibility according to GERG 88.

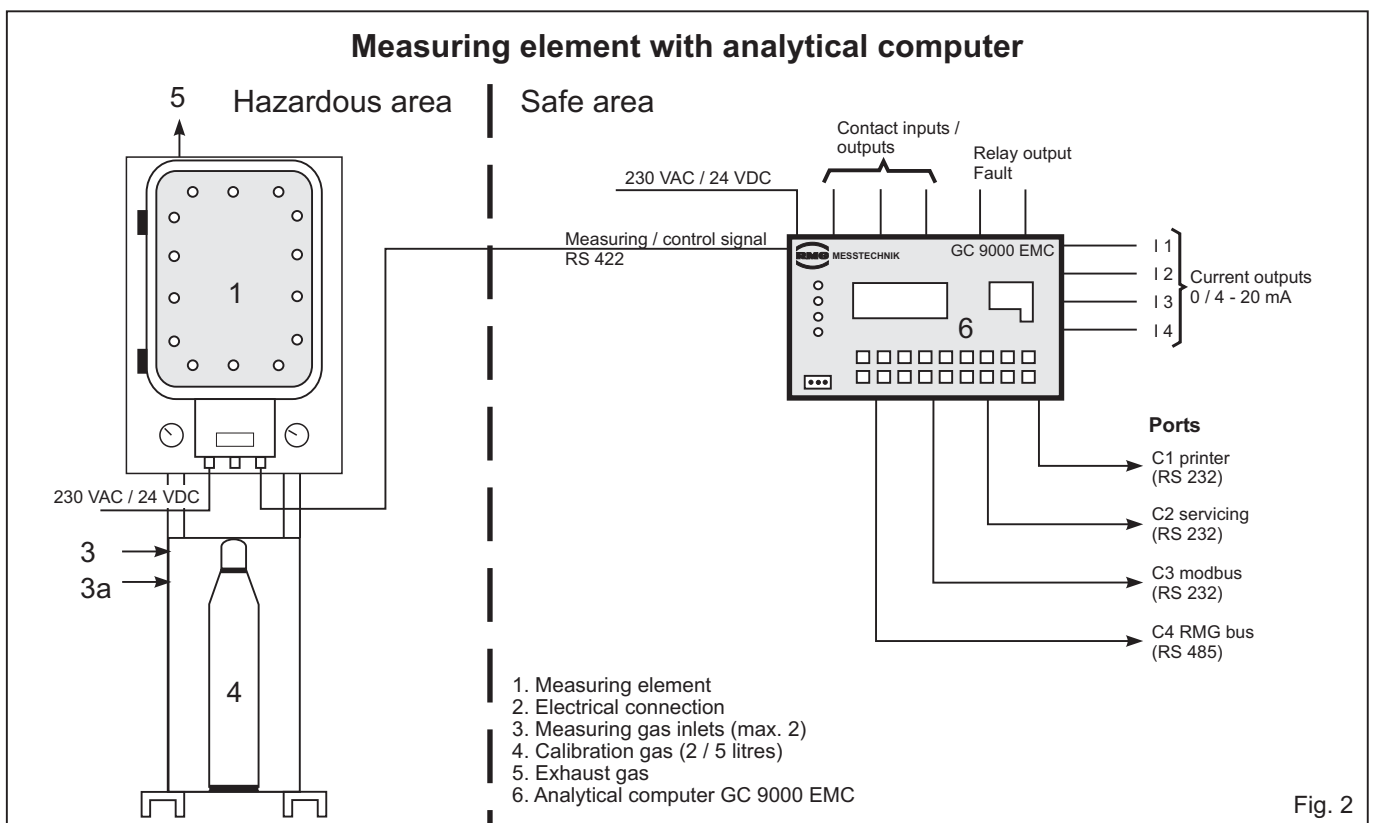

# Superior Calorific Value, Standard Density and Wobbe Index Measuring Device

## EMC 500

### Specifications

<b>Accuracy for natural gas<sup>1)</sup>:</b>	≤ 0.5% of the measured value ( $H_s$ and $\rho_n$ )	
<b>Measuring ranges gas:</b>	<u>Secondary metering</u>	<u>Fiscal Metering</u>
	<i>natural gas / other fuel gases</i>	<i>natural gas</i>
standard density $\rho_n$ :	0.65 – 1.3 / 0.3 – 2 kg/Nm <sup>3</sup>	0.71 – 0.97 kg/Nm <sup>3</sup>
superior calorific value $H_s$ :	7 – 14 / 2 – 25 kWh/Nm <sup>3</sup>	8.4 – 13.1 kWh/Nm <sup>3</sup>
carbon dioxide content $CO_2$ :	0 – 20 / 0 – 20 mol%	0 – 5 or 0 – 20 mol%
Wobbe index $W_s$ :	8 – 16 / 3 – 25 kWh/Nm <sup>3</sup>	
inferior calorific value $H_i$ :	7 – 14 / 2 – 25 kWh/Nm <sup>3</sup>	
methane number (option) MN:	40 – 100 ±2 / –	
<b>Gas consumption:</b>	max. 15 NI/h	
<b>Inlet pressure range:</b>	0.5 – 3.0 bar	
<b>Ambient temperature range:</b>	-20 – +55°C	
<b>Degree of protection:</b>	Ex design: IP 54	Non-Ex design: IP 43
<b>Ex device protection type:</b>	II 2G EEx de IIB T4	Appr. no.: DMT 02 ATEX E 035
<b>Response times<sup>2)</sup>:</b>	T50: ≤ 30 s T90: ≤ 60 s	
<b>Calibration time:</b>	8 min	
<b>Current outputs:</b>	up to 4 outputs, electrically isolated 0/4 – 20 mA freely programmable maximum load 700 Ω	
<b>Relay contacts:</b>	Changeover contacts, $U_{max}=24$ V, $P_{max}=100$ mW - fault relay (alarm) - "Calibration running" relay	
<b>Ports:</b>	2 x RS 232 C / V24	
<b>Power supply:</b>	230 / 115 V AC or 24 V DC	
<b>Power requirement:</b>	Measuring element: approx. 40 W (in the start-up phase 100 W) Analytical computer: 35 W	
<b>Measuring gas connection:</b>	Standard 1/8" Swagelok (option: 4 mm Swagelok)	
<b>Outlet pipe connection:</b>	Standard 6 mm Swagelok	
<b>Dimensions (wall mounting plate):</b>	W x H = 504 x 650 mm, D = 340 mm (Ex) or 290 mm (Non-Ex)	
<b>Weight (basic device):</b>	Ex design: approx. 50 kg	Non-Ex design: approx. 35 kg
<b>Safety features:</b>	Pressure / temperature monitoring (alarm)	

1) Accuracy for other fuel gases on request

2) Indicates the time after which the analytical result has followed a previous change in the gas composition by

**RMG Messtechnik GmbH**



**Publication No. 7.121-E**

P.O.Box 280 · D-35502 Butzbach (Germany)  
Tel.: +49 (0)6033 897-0 · Fax: +49 (0)6033 897-130  
E-mail: messtechnik@rmg.de · Internet: <http://www.rmg.de>

Issue 01/2005  
Subject to technical modification  
without notice.