

Valve plug

for H4 above ground hydrants

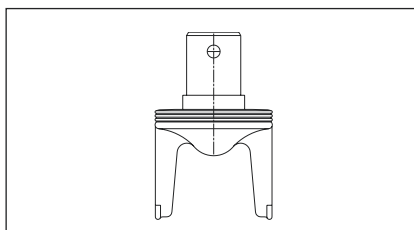

Order no.	DN	Weight kg	
5440	80-100	1,15	●

Coupling

for above ground hydrants

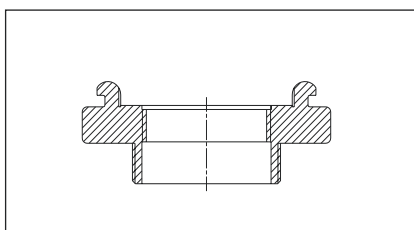

Order no.	Type	Weight kg	
5403	A coupling 4" DIN 14319	1,60	●
5404	B coupling 2½" DIN 14318	0,40	●
5405	C coupling 2" DIN 14317	0,22	●

Cap

for above ground hydrants

with chain and gasket

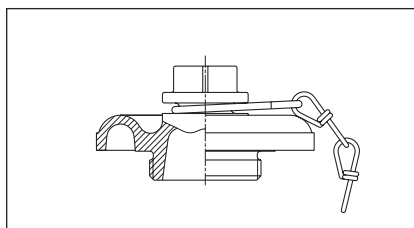

Order no.	for	Weight kg	
5400	A coupling	3,45	●
5401	B coupling	1,45	●
5402	C coupling	1,10	●

Operating Nut

for above ground hydrants

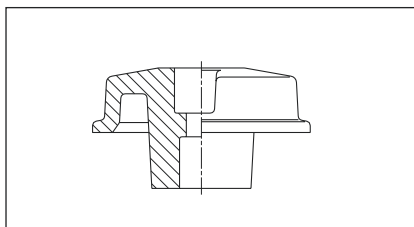

Order no.	Weight kg	
5415	1,80	●

Flat gasket

for cap

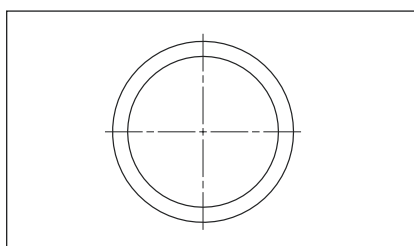

Order no.	for	Weight kg	
5406	A-cap	0,15	●
5407	B-cap	0,09	●
5408	C-cap	0,05	●

O ring

for coupling

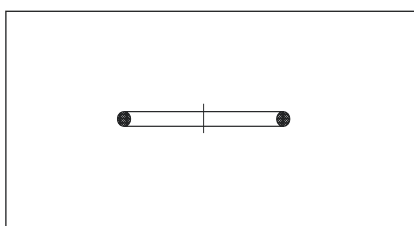

Order no.	for	Weight kg	
5410	A coupling	0,006	●
5411	B coupling	0,004	●
5412	C coupling	0,003	●

Spare Parts

Air Valve for above ground hydrant

of POM

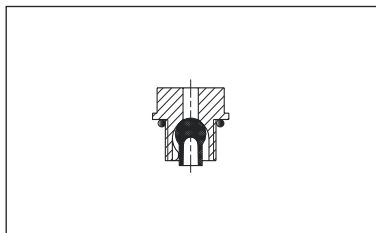

Order no.	Thread	Weight kg	
5180	3/8"	0,02	●

Bayonet Coupling

without cap

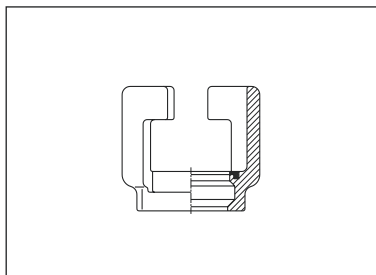

Order no.	for	Weight kg	
5171	Below ground hydrant DN 80	4,40	●
5170	Garden hydrant DN 50	2,70	●

Colour Repairs

blue synthetic resin coating,
UV resistant

Attention! Not suitable for potable water

Colour repairs for potable water on request



Order no.	Contents of can	
3441	1 kg	●

Repair Cartridge

for powder coated Hawle products

For repairing minor mechanical damage caused by transport or installation.

Cartridge with plunger

Exact 1:1 proportional dosing of resin and hardener.

Good mixing is essential.

For repairing large areas we recommend No. 3441 (see above).

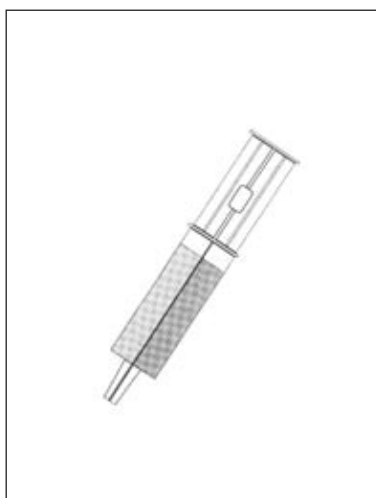

Order no.	Cartridge content	
3442	32 cm ³	●