

Order no.	Colour / RAL	DN	Outlet			Weight kg	
			A	B	C		
5151H4	red* / 3003	80		1	2	59,0	●
5151H4B	blue** / 5003		●				
5140H4	red* / 3003	80		2		58,0	●
5140H4B	blue** / 5003		●				
5151H4	red* / 3003	100	1	2		62,0	●
5151H4B	blue** / 5003		●				
5140H4	red* / 3003	100		2		59,0	●
5140H4B	blue** / 5003		●				

* standard colour red ** special colour blue - other colours on request

Standard: ÖNORM F 2010 — DIN 3222
Tested acc. to: ÖVGW / DVGW
Max. working pressure: 16 bar
Standard pipe cover: 1,50 m (on request 1,25 m and 1,00 m possible)
Remaining water content: "0" according DIN 3321



Instructions for use: see page I 8
Theft indicator cap: see page D 5/1
Security cap: see page D 4/2
Operating key: see page K 3/2
Other pipe cover: double flanged pipe see page L 1/1

Design features:

- entirely of corrosion free materials
- O rings embedded in non-corrosive material (according DIN 3547-T1)
- minimum torque for operation
- noticeable stop at the limits when opening and closing
- hydrant head can be turned from 0° to 360°
- automatic drain off system with pressure control
- drain outlet connection possible with PE pipe Ø 32 mm
- easy exchange of all inner parts
- several outlets on the stand pipe possible, positions on request
- outlets according to other standards possible

Hydrant head: sea water proof tempered aluminium alloy, UV resistant coated
Stand pipe: thick walled stainless steel tube, polished
Operating controls: stainless steel
Base: cast stainless steel
Rate of flow: rate of flow Q (m³/h) at a differential pressure of 1 bar is for all HAWLE H4-Hydrants higher than requested by ÖNORM F 2010 and DIN 3222



H4 Corrosion Free Hydrant - rigid type

Required details for ordering spare parts:
 order no. / DN / pipe cover / year of construction
 (see identification plate on back of the hydrant head)

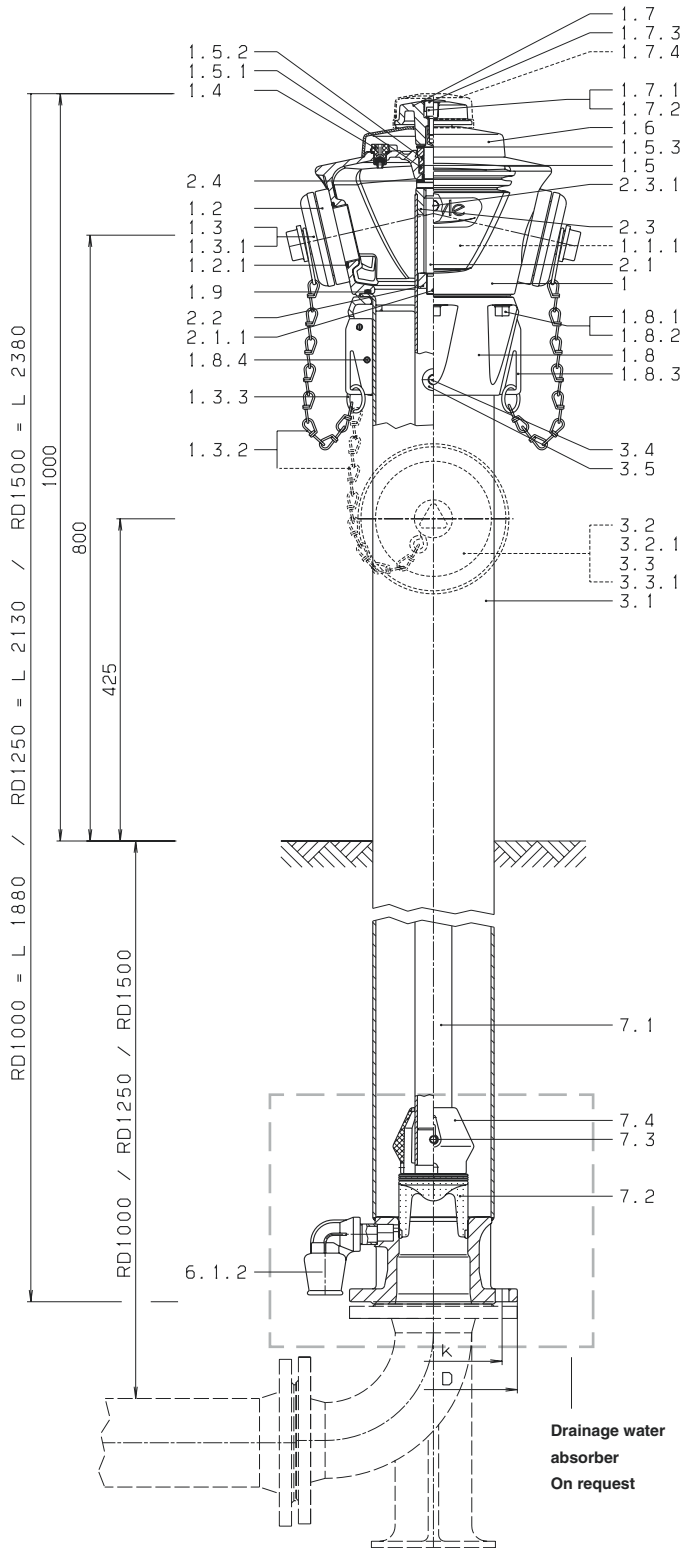

Parts	Material
1 Hydrant head	G-Al
1.1.1 Identification plate	various
1.2 DN 80 C coupling DIN 14317 - C1 52 mm DN 100 B coupling DIN 14318 - B1 75 mm	Al
1.2.1 DN 80 O-ring 64 x 4 DN 100 O-ring 79 x 4	elastomer
1.3 DN 80 C cap DIN 14317 - C 4 DN 100 B cap DIN 14318 - B 4	G-Al
1.3.1 DN 80 C flat seal ring DIN 14317 - C3 DN 100 B flat seal ring DIN 14318 - B3	elastomer
1.3.2 Chain with S-hooks	A2
1.3.3 Ring for chain	A2
1.4 Air valve	POM
1.5 O ring bush	brass
1.5.1 O ring 32 x 4	elastomer
1.5.2 O ring 25 x 3,5	elastomer
1.5.3 Friction washer	POM
1.6 Cap	G-Al
1.7 Operating nut	G-Al
1.7.1 Washer DIN 125 - A 13	A2
1.7.2 Allen bolt DIN 912 - M 12 x 25	A2
1.7.3 Isolating cap	PE
1.7.4 Theft safety device	polystyrene
1.8 Head flange for hydrant head	G-Al
1.8.1 Washer DIN 433 - 13	A2
1.8.2 Allen bolt DIN 912 - M 12 x 40	A2
1.8.3 Fixing strap	A2
1.8.4 Brace DIN 1481 - 8 x 16	A2
1.9 O ring 170 x 6	elastomer
2.1 Spindle rigid	A2
2.1.1 Pin DIN 94 - 4 x 25	A2
2.2 Stop nut	A2
2.3 Stem nut	brass
2.3.1 Hexagonal bolt DIN 933 - M 8 x 10	A2
2.4 Friction washer	POM
3.1 Stand pipe	A2
3.2 DN 80 B coupling DIN 14318 - B1 75 mm DN 100 A coupling DIN 14319 - A1 110 mm	Al
3.2.1 DN 80 O ring 79 x 4 DN 100 O ring 116 x 4	elastomer
3.3 DN 80 B cap DIN 14318 - B 4 DN 100 A cap DIN 14319 - A 4	G-Al
3.3.1 DN 80 B flat seal ring DIN 14318 - B3 DN 100 A flat seal ring DIN 14319 - A3	elastomer
3.4 Guide pin	A2
3.5 Guide bush	POM
6.1.2 Fitting 1" / 90°	POM
7.1 Operating controls	A2
7.2 Valve plug	brass/elastomer
7.3 Securing pin for valve plug	A2
7.4 Flow former	PE

DN	Outlets			Pipe cover RD	Base flange according EN 1092-1, drilled to DIN 2501				
	A	B	C		DN	D	k	Bolts	Qty.
80		1	2	1500 1250	80	200	160	M 16	8
		2							
100	1	2		1000	100	220	180	M 16	8
		2							