

| Order no. | Version | | Dimensions/DN | | | | | | | | | | | | | | |
|-------------|---|--------|---------------|----|----|-----|-----|-----|-----|-----|-----|-----|-----|-----|-----|-----|---|
| | | | 50 | 65 | 80 | 100 | 125 | 150 | 200 | 250 | 300 | 350 | 400 | 450 | 500 | 600 | |
| 3500 | Universal Pipe Saddle with female threaded outlet | 1" | ● | ● | ● | ● | ● | ● | ● | ● | ● | ● | | | | | |
| | | 1¼" | ● | ● | ● | ● | ● | ● | ● | ● | ● | ● | | | | | |
| | | 1½" | | | ● | ● | ● | ● | ● | ● | ● | ● | | | | | |
| | | 2" | | | ● | ● | ● | ● | ● | ● | ● | ● | ● | ● | ● | ● | ● |
| | | 2½" | | | | | | | ● | ● | | | | | | | |
| | | 3" | | | | | | | ● | ● | ● | ● | | | | | |
| 3510 | Universal Pipe Saddle with flanged outlet | DN 40 | | | ● | ● | ● | ● | ● | ● | ● | | | | | | |
| | | DN 50 | | | ● | ● | ● | ● | ● | ● | ● | | | | | | |
| | | DN 80 | | | | | | | ● | ● | ● | ● | ● | ● | ● | ● | ● |
| | | DN 100 | | | | | | | ● | ● | ● | ● | ● | ● | ● | ● | ● |
| | | DN 150 | | | | | | | | | | | | ● | ● | ● | ● |
| 3530 | Undrilled Saddle (see page F 1/2) | | ● | ● | ● | ● | ● | ● | ● | ● | | ● | ● | ● | ● | ● | |

larger sizes on request; surcharge for electrical earthing arrangement

for DCI, steel and AC pipes

Please specify pipe material on order
up to PN 16

Design features

- stainless steel rubber insulated strap
- solid epoxy powder coated body
- favourable angle of contact
- flexible wrap around straps for easy installation
- the saddle seal is moulded to fit the pipe diameter and is prefixed in the saddle body
- easily accessible nut on stainless steel dished washer (No. 3500/3530) resp. on stainless steel flat washer (No. 3510)

No. 3510
with flanged outlet



No. 3500
with female thread



Universal Pipe Saddle, Undrilled Saddle

| | | | |
|-----------------|---|-------------------|---|
| Material | | Strap insulation: | elastomer |
| Saddle body: | ductile iron, epoxy powder coated | Bolts: | M 16 - stainless steel 1.4408 DIN 17006 (G-X6 Cr NiMo 18 10) |
| Saddle seal: | elastomer, suitable for potable water | Nuts: | DIN 934, rust & acid proof steel 1.4401, DIN 17006 (X5 CrNiMo 18 10) molybdenum coating |
| Strap: | 1.5 mm gauge, stainless steel 1.4571 DIN 17006 (X10 CrNiMoTi 18 10) | | |

No. 3500 Universal Pipe Saddle with female threaded outlet DIN 2999 used in conjunction with shut-off adaptor no. 3720 for under pressure drilling

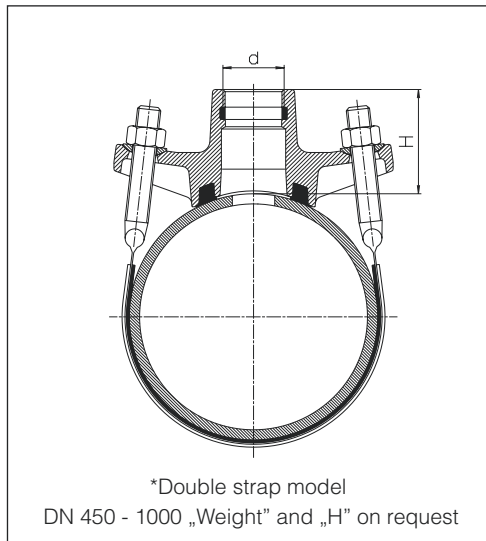

| Threaded outlet | | Dimensions/DN | | | | | | | | | | |
|-----------------|--------|---------------|------|------|------|------|------|------|------|------|------|------|
| | | 50 | 65 | 80 | 100 | 125 | 150 | 200 | 250 | 300 | 350 | 400 |
| 1" | Weight | 2,30 | 2,20 | 2,40 | 2,50 | 3,30 | 3,40 | 3,90 | 4,60 | 4,70 | | |
| | H | 64 | 64 | 61 | 61 | 78 | 78 | 86 | 89 | 89 | | |
| 1¼" | Weight | 2,30 | 2,20 | 2,40 | 2,50 | 3,40 | 3,50 | 4,10 | 4,60 | 4,70 | | |
| | H | 64 | 64 | 61 | 61 | 78 | 78 | 86 | 89 | 89 | | |
| 1½" | Weight | | | 2,40 | 2,50 | 3,60 | 3,60 | 4,20 | 4,80 | 4,90 | | |
| | H | | | 57 | 57 | 78 | 78 | 86 | 89 | 89 | | |
| 2" | Weight | | | 2,45 | 2,50 | 3,80 | 3,90 | 4,40 | 5,00 | 5,10 | 6,40 | 6,60 |
| | H | | | 57 | 57 | 78 | 78 | 86 | 89 | 89 | 74* | 74* |
| 2½" | Weight | | | | | | 5,30 | 5,70 | | | | |
| | H | | | | | | 54* | 56* | | | | |
| 3" | Weight | | | | | | 5,40 | 5,40 | 5,90 | 6,00 | | |
| | H | | | | | | 54* | 56* | 56* | 56* | | |

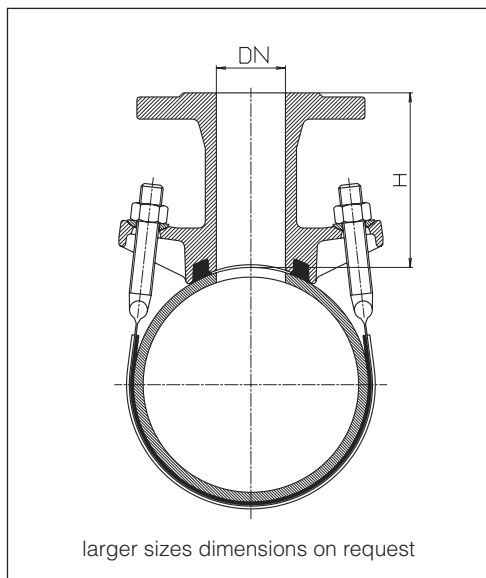

No. 3510 Universal Pipe Saddle with flanged outlet - DIN 28504 all models have a double strap, flange drilling to DIN 2501 - PN 16

| Flanged outlet DN | | Dimensions/DN | | | | | | | | | | | |
|-------------------|--------|---------------|------|------|-------|-------|-------|-------|-------|-------|-------|-------|-------|
| | | 80 | 100 | 125 | 150 | 200 | 250 | 300 | 350 | 400 | 450 | 500 | 600 |
| 40 | Weight | 6,60 | 6,60 | 6,80 | 6,90 | 7,70 | 7,90 | 8,00 | | | | | |
| | H | 114 | 114 | 126 | 126 | 145 | 153 | 153 | | | | | |
| 50 | Weight | 6,60 | 6,60 | 6,80 | 6,90 | 7,70 | 7,90 | 8,00 | | | | | |
| | H | 114 | 114 | 126 | 126 | 145 | 153 | 153 | | | | | |
| 80 | Weight | | | | 8,80 | 10,00 | 10,40 | 10,50 | 11,00 | 12,20 | 12,30 | 12,50 | 11,80 |
| | H | | | | 135 | 150 | 147 | 147 | 146 | 146 | 146 | 146 | 146 |
| 100 | Weight | | | | 10,30 | 10,10 | 11,60 | 11,70 | 12,50 | 12,70 | 12,80 | 12,90 | 13,30 |
| | H | | | | 140 | 155 | 158 | 158 | 165 | 165 | 165 | 165 | 165 |
| 150 | Weight | | | | | | | | | 27,50 | 28,00 | 29,00 | 30,50 |
| | H | | | | | | | | | 186 | 186 | 186 | 186 |

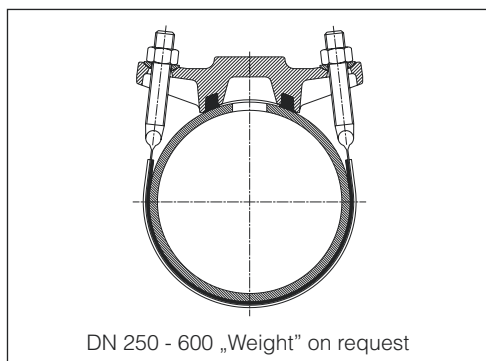

No. 3530 Undrilled Saddle ductile iron, epoxy powder coated suitable for covering of drill holes up to Ø 40 mm

| Dimensions / DN | 65 | 80 | 100 | 125 | 150 | 200 |
|-----------------|------|------|------|------|------|------|
| Weight kg | 2,60 | 2,70 | 2,70 | 3,50 | 3,60 | 4,30 |