

## No. 8653

### Suction Strainer

of stainless steel 1.4301



DN	Length	Weight	
50	300	0,9	●
65		1,1	●
80		1,3	●
100		1,5	●
125		1,9	●
150		2,4	●
200		3,2	●

other dimensions on request

## No. 3470

### Flat Gasket

with fabric liner

of elastomer, suitable for potable water

## No. 3390

### Flat Gasket

steel reinforced

keeps its shape and therefore easy to position

of elastomer, suitable for potable water

Standard version PN 10

PN 16 and PN 25 on request

No. 3470

No. 3390

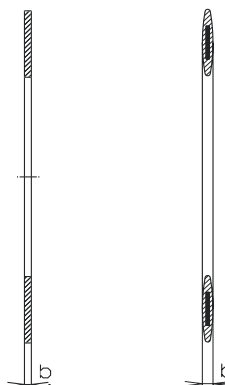

DN	b No.		Weight kg		
	3470	3390	3470	3390	
50	3	4	0,02	0,04	●
65	3	4	0,03	0,06	●
80	3	4	0,04	0,07	●
100	3	5	0,04	0,07	●
125	3	5	0,05	0,12	●
150	4	5	0,06	0,13	●
200	4	6	0,10	0,18	●
250	4	6	0,13	0,23	●
300	4	6	0,17	0,60	●
350	4	7	0,21	0,70	●
400	4	7	0,23	0,77	●

## Enlarging Sleeve

for flange adaptors

to increase pipe outside diameter to fit flange adaptor

### No. 7540 Sleeve gauge 2 mm

(60 mm wide)

### No. 7560 Sleeve gauge 3 mm

(80 mm wide)

Please specify pipe material and diameter

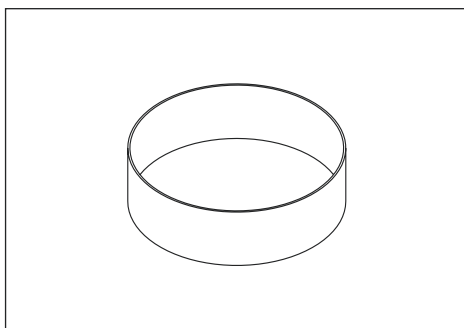

DN	
50	●
65	●
80	●
100	●
125	●
150	●
200	●
250	●
300	●
350	●
400	●

# Accessories

## No. 8730

### Angle Piece adjustable 0°–8°

of steel, galvanized

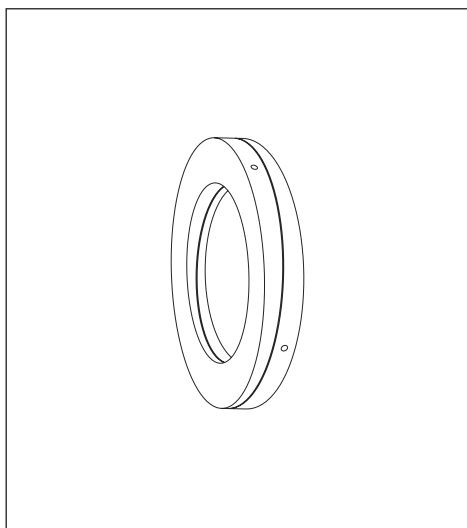

DN	Weight kg	
80	1,70	●
100	2,00	●
125	2,90	●
150	3,70	●
200	5,20	●
250	7,70	●
300	9,10	●
350	17,50	●
400	21,50	●

Angle Piece adjustable mm		
DN	bei 0°	bei 8°
80	27	18/37
100	25	14/38
125	29	16/43
150	33	18/48
200	35	18/56
250	40	22/65
300	44	21/70
350	55	28/85
400	57	28/90

## No. NL 47

### Endcap

with socket for CI pipes  
PN 16

of ductile iron  
epoxy powder coated

(suitable restraint „Hawle-Stop“ No. NL80  
see page A 5/1a)

threaded outlet 1"

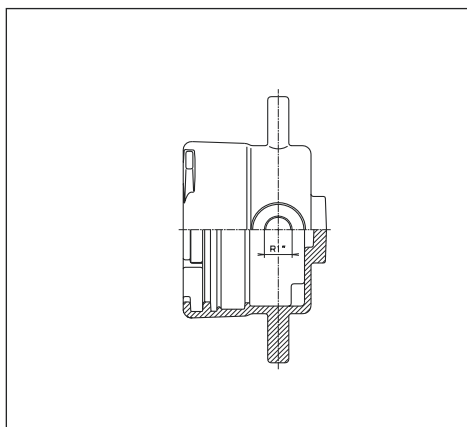

DN	Pipe Ø mm	Weight kg	
80	98	5,00	●
100	118	5,40	●
125	144	7,90	●
150	170	8,50	●
200	222	13,00	●

## Theft indicator

for HAWLE-Above Ground Hydrants

effective protection against unauthorised  
access

-for Hawle Hydrants supplied after 1997

(for Hawle Hydrants supplied before please  
specify in your inquiry)



Theft indicator			
Order no.	Outlet	Weight	
5397	for A-coupling	3,70	●
5398	for B-coupling	2,20	●
5399	for C-coupling	1,70	●
Adaptor			
Order no.	for coupling	Weight	
3453	A + B + C	0,50	●

## Adaptor

Opening of Hydrant solely with adaptor  
and operating key no. 3460 (see page  
K 3/2) possible

