

rigid or telescopic

for E2 Valves and E2 Combi Valves DN 50 - 200

- one extension spindle for several dimensions
- protective cover with integrated locking mechanism
- No additional fixing (bolt/pin) necessary

Order no.	Version	Pipe cover depth	for dimensions/DN		
			50/65/80/100	125/150	200
8980E2	rigid	1,00 m	●	●	●
8990E2	rigid	1,25 m	●	●	●
9000E2	rigid (standard)	1,50 m	●	●	●
9010E2	rigid	2,00 m	●	●	●
9020E2	rigid	2,50 m	●	●	●
9500E2	telescopic	1,30 - 1,80 m	●	●	
9500E2	telescopic	1,35 - 1,80 m			●
9510E2	telescopic	2,00 - 2,50 m	●	●	●

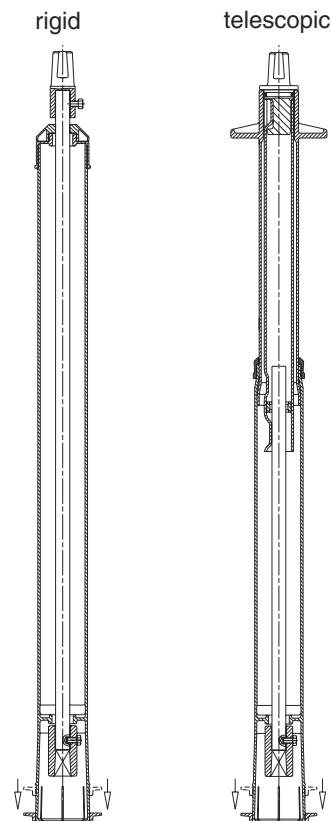

for E2 Valve DN 250 - 600

Order no.	Version	Pipe cover depth	for dimensions/DN						
			250	300	350	400-500*	500	600	
8980	rigid	1,00 m	●	●					
8990	rigid	1,25 m	●	●	●	●			
9000	rigid (standard)	1,50 m	●	●	●	●			
9010	rigid	1,90 m						●	
9010	rigid	2,00 m	●	●	●	●			●
9020	rigid	2,40 m						●	
9020	rigid	2,50 m	●	●	●	●			●
9500	telescopic	1,40 - 1,80 m	●						
9500	telescopic	1,50 - 1,80 m		●	●	●			
9510	telescopic	1,90 - 2,20 m						●	
9510	telescopic	2,00 - 2,30 m							●
9510	telescopic	2,00 - 2,50 m	●	●	●	●			

* Body: DN 400 – flange connection: DN 450 or 500

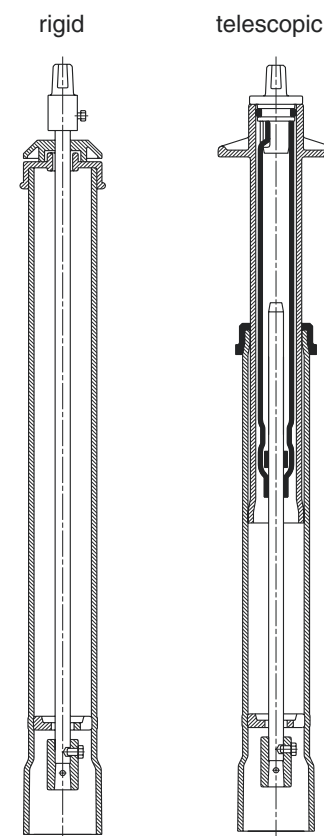

E2 Extension Spindles

All extension spindles (fixe and télescopique) of all types and dimensions are protected against dirt and surface water.

The **télescopique extension spindle** can be progressively adjusted to the ground level.

This is done by pushing or pulling the tube and the spindle shaft.

The télescopique effect protects the pipe and fitting from surface impact. Supplied with or without surface box and base plate.

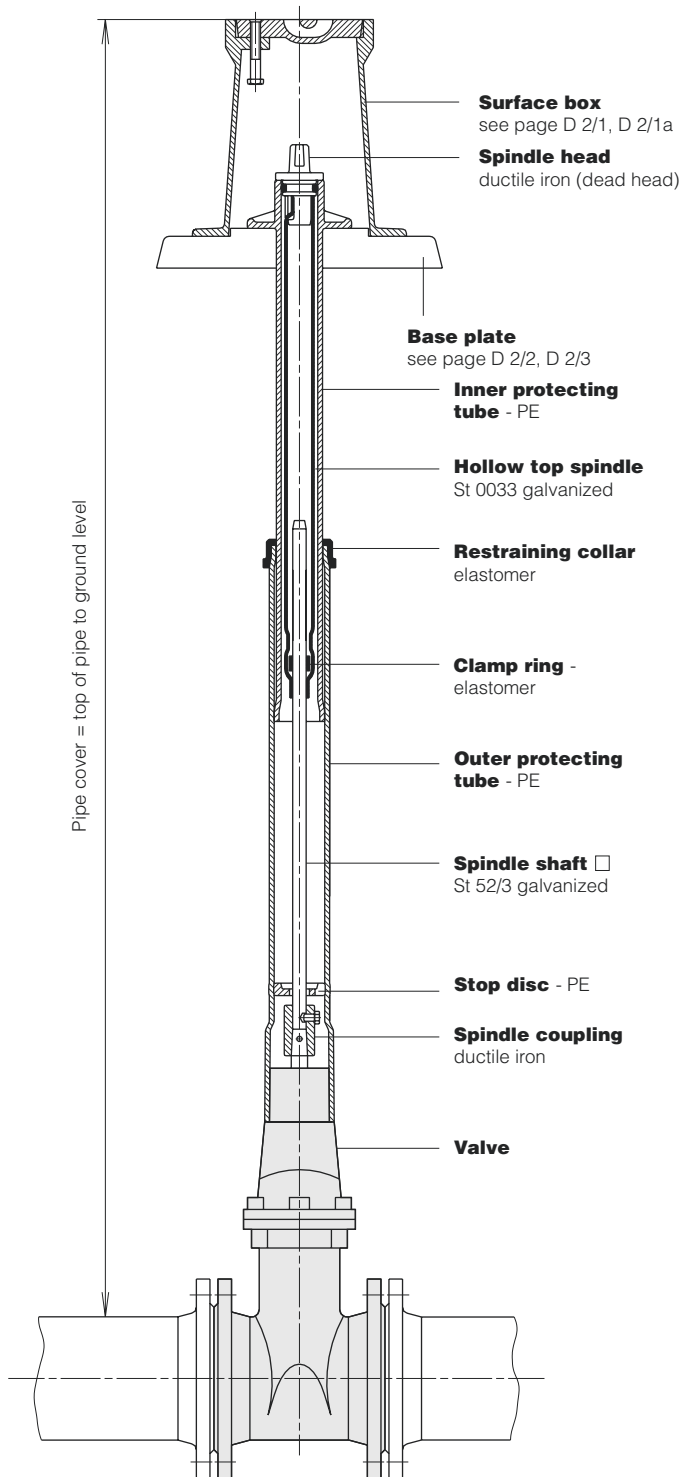
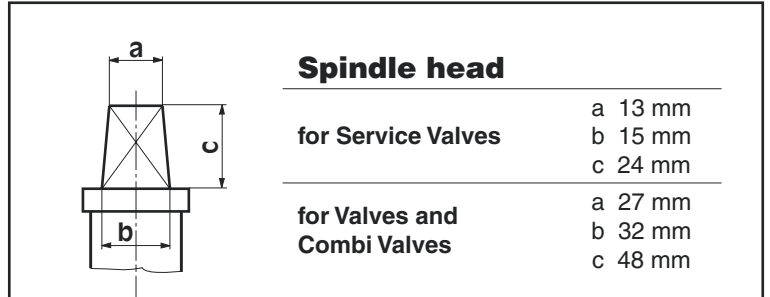

Illustration: **Télescopique Extension Spindle DN 250 - 600**



Weight of Extension Spindle for E2 Valves and E2 Combi Valves DN 50 - 200

DN	Weight kg for order no.						
	8980E2	8990E2	9000E2	9010E2	9020E2	9500E2	9510E2
50-100	3,45	4,45	5,40	7,45	9,50	6,75	9,40
125-150	2,90	3,90	4,90	6,90	8,90	6,25	8,90
200	2,70	3,70	4,70	6,70	8,70	6,10	8,60

Weight of Extension Spindle for E2 Valves DN 250-600

DN	Weight kg for order no.						
	8980	8990	9000	9010	9020	9500	9510
250	3,20	4,70	6,15	9,15	12,30	7,30	11,10
300	2,90	4,40	5,85	8,80	12,00	6,85	10,70
350		4,00	5,50	8,45	11,60	6,60	10,30
400-500		3,55	5,00	8,00	11,00	6,25	9,80
500-600				7,40	9,70		8,70

Illustration: Assembly of E2 Extension Spindle DN 50-200

