

Order no.	PN	Dimension/DN Pipe Ø mm												
		50 63	65 75	80 90	100 110	100 125	125 140	150 160	150 180	200 200	200 225	250 250	250 280	300 315
<b>4041E2</b>	16	●	●	●	●	●	●	●	●	●	●	●	●	●

## Resilient seated gate valve with flange and socket for PE (PE 80/100) and PVC pipes (DIN 8074, 8061 / 8062) - total restraint

### Material and design features:

- 1/2/16 **Body (1) bonnet (2) and lock ring (16)** of ductile iron EN-GJS-400-18 according to EN 1563 (GGG 400 - DIN 1693) inside and outside epoxy powder coated according to DIN 30677-T2 in accordance with DIN 3476 and all quality and test requirements of RAL quality mark 662 (GSK - Gütegemeinschaft Schwerer Korrosionsschutz - the association for high quality corrosion protection)
- 3 **Stainless steel spindle** St 1.4021 (X20Cr13), with rolled thread and O ring slide faces
- 4 **Wedge** of ductile iron EN-GJS-400-18 according to EN 1563 (GGG 400 - DIN 1693), inside and outside fully rubberized with vulcanized elastomer, suitable for potable water, with drain hole
- 5 **Wedge guide** of wear resistant plastic with high gliding features; optimally placed design guarantees lowest wear and tear and lowest closing torques
- 6 **Wedge nut** of dezincification resistant brass CuZn36Pb3As, generous oversizing of the required thread length in the wedge nut guarantees highest possible breaking torques
- 7 **O ring bush** of Ms 58
- 8 **O rings** of elastomer, embedded in non-corrosive material (according to DIN 3547-T1) and replaceable under pressure up to DN 200 (according to ISO 7259), DN 250 and higher without pressure
- 9 **Back seal** of elastomer, suitable for potable water
- 10 **Circlip** of POM
- 11 **Wiper ring** of elastomer
- 12 **Bonnet gasket** of elastomer, suitable for potable water
- 13 **Allen screws** St 8.8 DIN 912 absolutely corrosion protected by being sunk into the body and sealed, and by passing through bonnet gasket
- 14 **Edge protecting ring** of PE avoids damages during transport and storage
- 15 **Friction washers** of POM guarantee smooth spindle guiding
- 17 **Grip ring** of Ms 58 (from DN 300 Rg 7)
- 18 **Lip seal** of elastomer, suitable for potable water
- 19 **Bolts and washers** of A2 (stainless steel)
- 20 **Spacer bushes** of PE

The pipe is sealed with a lip seal.

Minimal pipe insertion force is required for pushing the pipe end into the seal chamfer with an appropriate chamfer.

The pipe restraining system is effective separately from the sealing system and is activated by tightening the lock ring.

For thinwalled PE pipes (up to 3 mm wall thickness) and low internal pressure we recommend using a support liner (see page D 2/4).

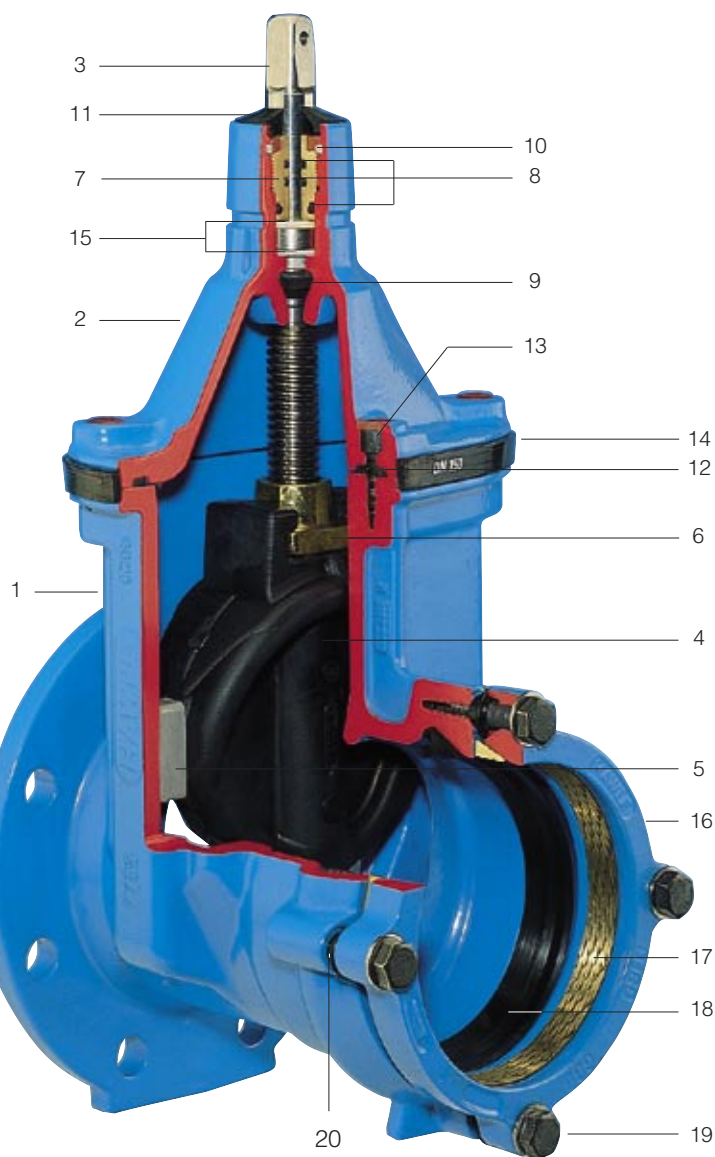

**Assembly instructions:** see page M 6/2  
**Tensile load:** see page M 6/2

**Flange** according to EN 1092-2, drilled to DIN 2501-PN10 (standard);  
 For DIN 2501-PN 16 in sizes of DN 200 mm and above please specify on order - other standards on request !

# E2 Valve Flange/socket SYSTEM 2000

**Standard version:** without handwheel and extension spindle

**Design versions:** for electric actuator: No.4041ELE2;  
with position indicator: No. 4041STE2

**Special versions:** on request

**Suitable accessories:** **Handwheel:** No. 7800

**Extension Spindles:** rigid No. 9000E2, from DN 250 No. 9000  
telescopic No. 9500E2, from DN 250 No. 9500

**Surface Boxes:** rigid No. 1750, telescopic No. 2050

## Design features:

- easy retrofitting of position indicator and automatic actuator on the standard bonnet
- one extension spindle for several dimensions
- optimally placed wedge guide of wear resistant plastic guarantees lowest wear and tear and lowest closing torques, suitable for frequent operations at a differential pressure up to 16 bar
- 100 % suitable for operation by automatic actuators
- generous oversizing of the required thread length in the wedge nut guarantees highest possible strength
- O rings embedded in non-corrosive material (according to DIN 3547-T1)
- replaceable O rings
  - up to DN 200 under pressure (according ISO 7259)
  - from DN 250 without pressure
- cleaning with pig possible

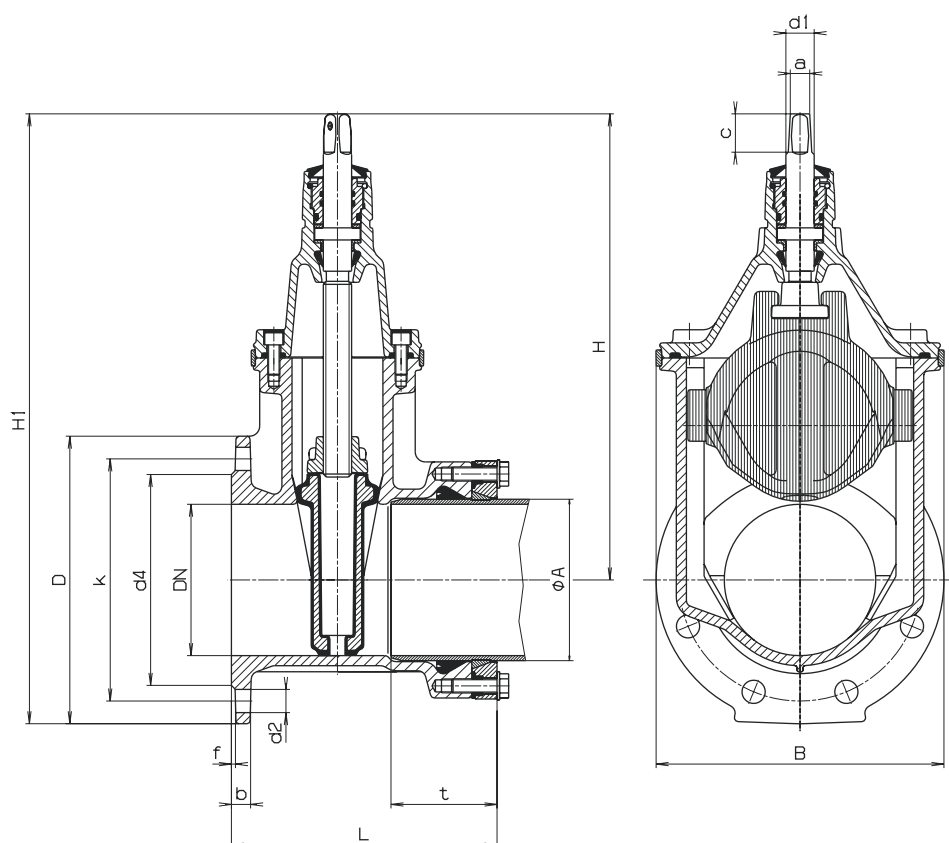

DN	PN	Pipe Ø mm	Flange					Bolts			Valve				Spindle			Weight kg	
			D	b	k	d 4	f	Qty.	Thread	d 2	t	H	H 1	L	B	a	c		d 1
50	10	63	165	19	125	98	3	4	M 16	19	83	260	342	188	143	14,8	30	22	10,5
	16																		
65	10	75	185	19	145	118	3	4	M 16	19	85	328	420	205	180	17,3	35	25	15,5
	16																		
80	10	90	200	19	160	133	3	8	M 16	19	88	336	436	211	180	17,3	35	25	17,5
	16																		
100	10	110	220	19	180	153	3	8	M 16	19	88	373	483	221	213	19,3	38	25	22,0
	16																		
125	10	140	250	19	210	183	3	8	M 16	19	96	450	575	239	285	19,3	38	28	33,5
	16																		
150	10	160	285	19	240	209	3	8	M 20	23	108	462	605	263	285	19,3	38	28	40,0
	16																		
200	10	200	340	20	295	264	3	8	M 20	23	128	563	733	298	357	24,3	48	32	65,0
	16																		
250	10	250	400	22	350	319	3	12	M 20	23	147	670	870	325	432	27,3	48	34	102,0
	16																		
300	10	315	455	24,5	400	367	4	12	M 20	23	176	753	981	371	518	27,3	48	34	158,0
	16																		