

Order no.	PE-fusion tails	PN	Application	Dimensions/DN Pipe Ø mm											
				50 63	65 75	80 90	100 110	100 125	125 140	150 160	150 180	200 200	200 225		
<b>4090E2</b>	PE 80 / SDR 11	10	for cold water, non aggressive effluent other applications on request	●	●	●	●	●	●	●	●	●	●	●	
	PE 100 / SDR 11	16		●	●	●	●	●	●	●	●	●	●	●	●
<b>4091E2</b>	PE 80 / SDR 17.6	6		●	●	●	●	●	●	●	●	●	●	●	●
	PE 100 / SDR 17.6	10		●	●	●	●	●	●	●	●	●	●	●	●

please specify on order PE (standard PE 80)



## Resilient seated gate valve with flange and PE tail

for use with PE piping according to ÖNORM B 5172, DIN 8075,

of ductile iron, epoxy powder coated

### Material and design features:

- 1/2 **Body (1) and Bonnet (2)** of ductile iron EN-GJS-400-18 according to EN 1563 (GGG 400 - DIN 1693) inside and outside epoxy powder coated according to DIN 30677-T2 in accordance with DIN 3476 and all quality and test requirements of RAL quality mark 662 (GSK - Gütegemeinschaft Schwerer Korrosionsschutz - the association for high quality corrosion protection)
  - 3 **Stainless steel spindle** St 1.4021 (X20Cr13), with rolled thread and O ring slide faces
  - 4 **Wedge** of ductile iron EN-GJS-400-18 according to EN 1563 (GGG 400 - DIN 1693), inside and outside fully rubberized with vulcanized elastomer, suitable for potable water, with drain hole
  - 5 **Wedge guide** of wear resistant plastic with high gliding features; optimally placed design guarantees lowest wear and tear and lowest closing torques
  - 6 **Wedge nut** of dezincification resistant brass CuZn36Pb3As, generous oversizing of the required thread length in the wedge nut guarantees highest possible breaking torques
  - 7 **O ring bush** of Ms 58
  - 8 **O rings** of elastomer, embedded in non-corrosive material (according to DIN 3547-T1) and replaceable under pressure (according to ISO 7259)
  - 9 **Back seal** of elastomer, suitable for potable water
  - 10 **Circlip** of POM
  - 11 **Wiper ring** of elastomer
  - 12 **Bonnet gasket** of elastomer, suitable for potable water
  - 13 **Allen screws** St 8.8 DIN 912 absolutely corrosion protected by being sunk into the body and sealed, and by passing through bonnet gasket
  - 14 **Edge protecting ring** of PE avoids damages during transport and storage
  - 15 **Friction washers** of POM guarantee smooth spindle guiding
  - 16 **O ring** of elastomer, suitable for potable water
  - 17 **Socket seal** of elastomer, suitable for potable water
  - 18 **PE tails**  
standard version PE 80 injection moulded  
Melt flow rate: MFR 190/5 kg - 09  
MFR-group 010 (DIN 8075)  
(PE 100 MFR-group 05-DIN 8075)
- Support liner** for PE tails (see drawing over page)  
1.4301 (X5CrNi189)

**Flanges** according to EN 1092-2, drilled to DIN 2501 - PN 10

This resilient seated valve has one flange and one PE tail screwed into and sealed in the socket.

High performance sealing of the PE tail within the sockets is assured by two separate seals and a stainless steel support liner within the tail. The valve can be connected to the PE pipeline by either butt fusion or electrofusion.

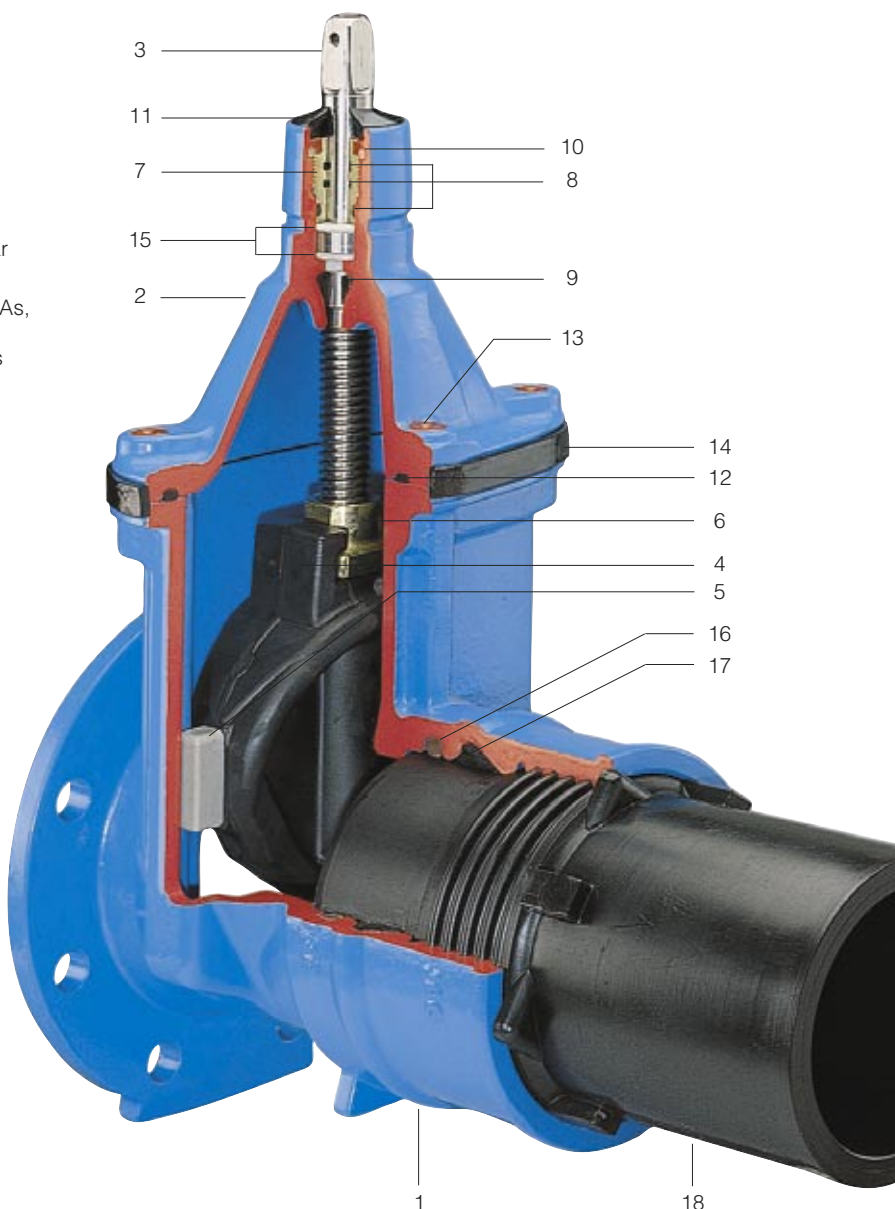

# E2 Elypso Valve Flange/PE tail

**Standard version:** without handwheel and extension spindle

**Design versions:** for electric actuator: No. 4090ELE2, No. 4091ELE2  
with position indicator: No. 4090STE2, No. 4091STE2

**Special versions:** on request!

**Suitable accessories:** **Handwheel:** No. 7800  
**Extension Spindles:** rigid No. 9000E2  
telescopic No. 9500E2

**Surface Boxes:** rigid No. 1750  
telescopic No. 2050

## Design features:

- easy retrofitting of position indicator and automatic actuator on the standard bonnet
- one extension spindle for several dimensions
- optimally placed wedge guide of wear resistant plastic guarantees lowest wear and tear and lowest closing torques, suitable for frequent operations at a differential pressure up to 16 bar
- 100 % suitable for operation by automatic actuators
- generous oversizing of the required thread length in the wedge nut guarantees highest possible strength
- O rings embedded in non-corrosive material (according to DIN 3547-T1)
- replaceable O rings under pressure (according to ISO 7259)
- cleaning with pig possible

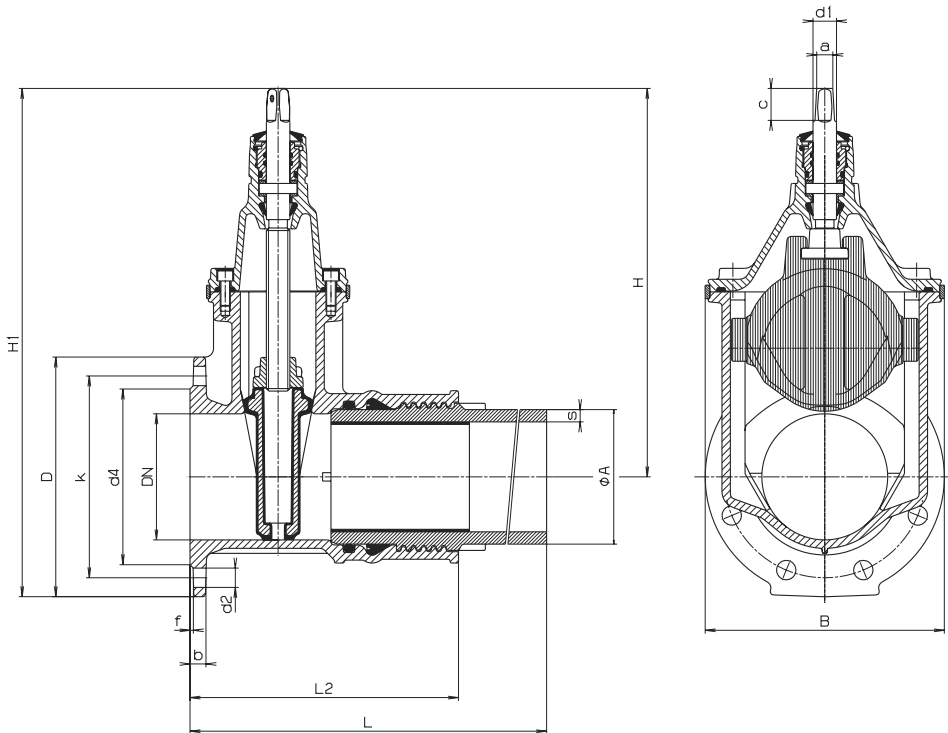

DN	Pipe Ø mm	Flange					Bolts			Valve with PE tail						Spindle			Weight kg	
		D	b	k	d 4	f	Qty.	Thread	d 2	s (PN 6)*	s (PN 10)**	H	H 1	L	L 2	B	a	c		d 1
50	63	165	19	125	98	3	4	M 16	19	3,6	5,8	260	342	399	215	143	14,8	30	22	11,5
65	75	185	19	145	118	3	4	M 16	19	4,3	6,9	328	420	416	235	180	17,3	35	25	17,5
80	90	200	19	160	133	3	8	M 16	19	5,1	8,2	336	436	425	245	180	17,3	35	25	18,5
100	110	220	19	180	153	3	8	M 16	19	6,3	10,0	373	483	450	265	213	19,3	38	25	26,0
100	125	220	19	180	153	3	8	M 16	19	7,1	11,4	373	483	476	293	213	19,3	38	25	28,0
125	140	250	19	210	183	3	8	M 16	19	8,0	12,8	450	575	485	310	285	19,3	38	28	39,5
150	160	285	19	240	209	3	8	M 20	23	9,1	14,6	462	605	503	320	285	19,3	38	28	46,0
150	180	285	19	240	209	3	8	M 20	23	10,4	16,4	462	605	512	334	285	19,3	38	28	50,5
200	200	340	20	295	264	3	8	M 20	23	11,4	18,2	563	733	565	372	357	24,3	48	32	78,5
200	225	340	20	295	264	3	8	M 20	23	12,8	20,5	563	733	565	372	357	24,3	48	32	79,5

\*SDR 17.6 \*\*SDR 11