

Order no.	PE-fusion tails	PN	Application	Dimensions/DN Pipe-Ø mm													
				25 32	32 40	40 50	50 63	65 75	80 90	100 110	100 125	125 140	150 160	150 180	200 200	200 225	
4050	PE 80 / SDR 11	10	for cold water, non aggressive effluent other application on request	●	●	●											
	PE 100 / SDR 11	16															
4051	PE 80 / SDR 17.6	6		●	●	●											
	PE 100 / SDR 17.6	10															
4050E2	PE 80 / SDR 11	10					●	●	●	●	●	●	●	●	●	●	●
	PE 100 / SDR 11	16															
4051E2	PE 80 / SDR 17.6	6					●	●	●	●	●	●	●	●	●	●	●
	PE 100 / SDR 17.6	10															

please specify on order PE (standard PE 80)

Resilient seated gate valve with PE fusion tails for use with PE piping according to ÖNORM B 5172, DIN 8075 of ductile iron, epoxy powder coated



Material and design features:

- 1/2 **Body (1) and bonnet (2)** of ductile iron EN-GJS-400-18 according to EN 1563 (GGG 400 - DIN 1693) inside and outside epoxy powder coated according to DIN 30677-T2 in accordance with DIN 3476 and all quality and test requirements of RAL quality mark 662 (GSK - Gütegemeinschaft Schwerer Korrosionsschutz - the association for high quality corrosion protection)
 - 3 **Stainless steel spindle** St 1.4021 (X20Cr13), with rolled thread and O ring slide faces
 - 4 **Wedge** of ductile iron EN-GJS-400-18 according to EN 1563 (GGG 400 - DIN 1693), inside and outside fully rubberized with vulcanized elastomer, suitable for potable water, with drain hole
 - 5 **Wedge guide** of wear resistant plastic with high gliding features; optimally placed design guarantees lowest wear and tear and lowest closing torques
 - 6 **Wedge nut** of dezincification resistant brass CuZn36Pb3As, generous oversizing of the required thread length in the wedge nut guarantees highest possible breaking torques
 - 7 **O ring bush** of Ms 58
 - 8 **O rings** of elastomer, embedded in non-corrosive material (according to DIN 3547-T1) and replaceable under pressure (DN 50 - 200, according to ISO 7259)
 - 9 **Back seal** of elastomer, suitable for potable water
 - 10 **Circlip** of POM
 - 11 **Wiper ring** of elastomer
 - 12 **Bonnet gasket** of elastomer, suitable for potable water
 - 13 **Allen screws** St 8.8 DIN 912 absolutely corrosion protected by being sunk into the body and sealed, and by passing through bonnet gasket
 - 14 **Edge protecting ring** of PE avoids damages during transport and storage
 - 15 **Friction washers** of POM guarantee smooth spindle guiding
 - 16 **O ring** of elastomer, suitable for potable water
 - 17 **Socket seal** of elastomer, suitable for potable water
 - 18 **PE tails**
standard version PE 80 injection moulded
Melt flow rate: MFR 190/5 kg - 09
MFR-group 010 (DIN 8075)
(PE 100 MFR-group 05-DIN 8075)
- Support liner** for PE tails (see drawing over page) 1.4301 (X5CrNi189)

This resilient seated valve has PE tails screwed into and sealed in the sockets.

High performance sealing of the PE tails within the sockets is assured by two separate seals and a stainless steel support liner within the tails.

The valve can be connected to the PE pipeline by either butt fusion or electrofusion.

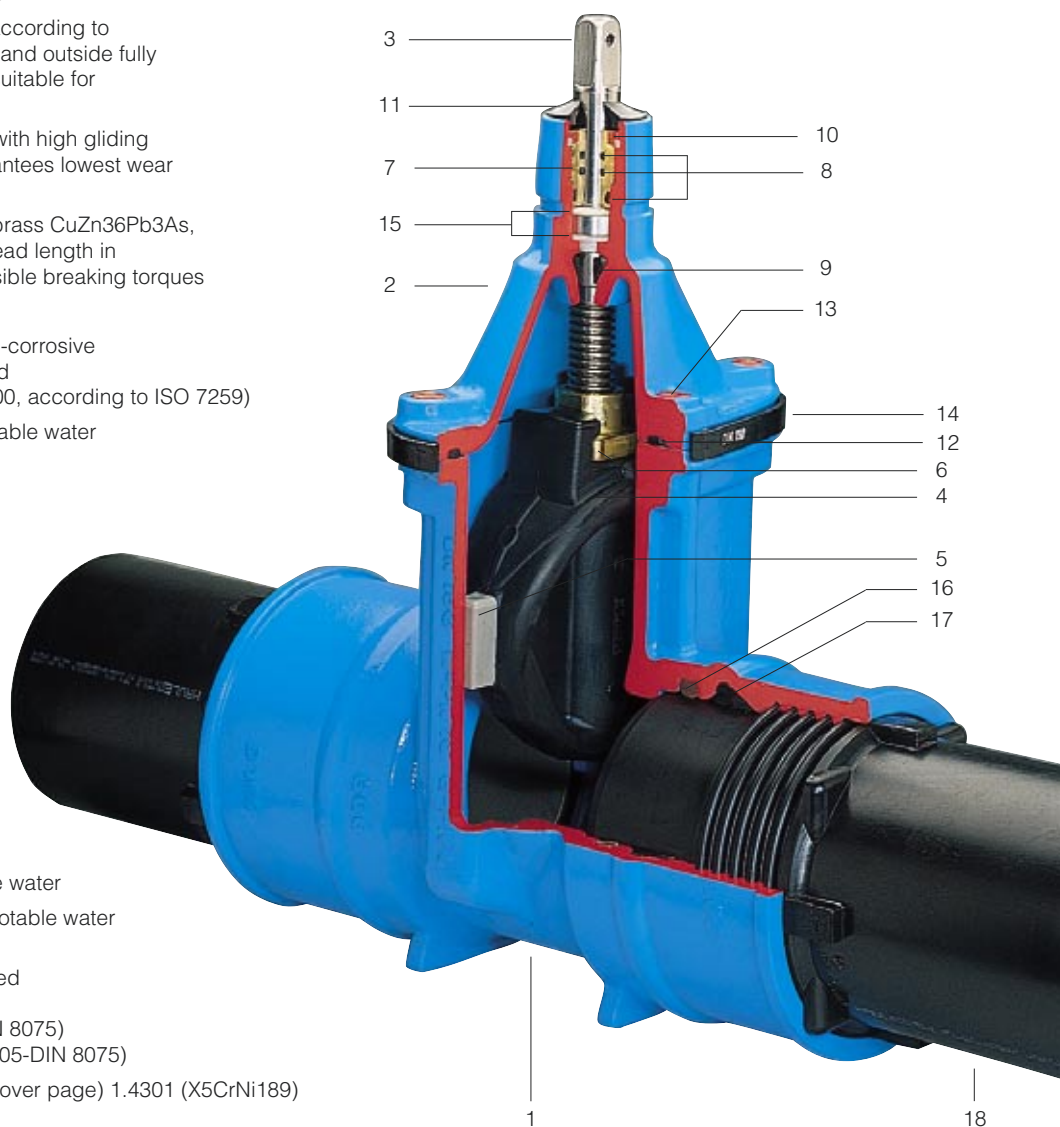

E2 Elypso Valve for PE fusion

Standard version:	without handwheel and extension spindle	
Design versions:	for electric actuator:	No. 4050ELE2, No. 4051ELE2
	with position indicator:	No. 4050STE2, No. 4051ELE2
Special versions:	on request	
Suitable accessories:	Handwheel:	No. 7800
	Extension Spindles:	rigid No. 9000E2, up to DN 40 No. 9101 Teleskopisch No. 9500E2, up to DN 40 No. 9601
	Surface Boxes:	rigid No. 1750, telescopic No. 2050

Design features:

DN 50 - DN 200

- easy retrofitting of position indicator and automatic actuator on the standard bonnet
- one extension spindle for several dimensions
- optimally placed wedge guide of wear resistant plastic guarantees lowest wear and tear and lowest closing torques, suitable for frequent operations at a differential pressure up to 16 bar
- 100 % suitable for operation by automatic actuators
- generous oversizing of the required thread length in the wedge nut guarantees highest possible strength
- O rings embedded in non-corrosive material (according to DIN 3547-T1)
- replaceable O rings under pressure (DN 50 - 200, according ISO 7259)
- cleaning with pig possible

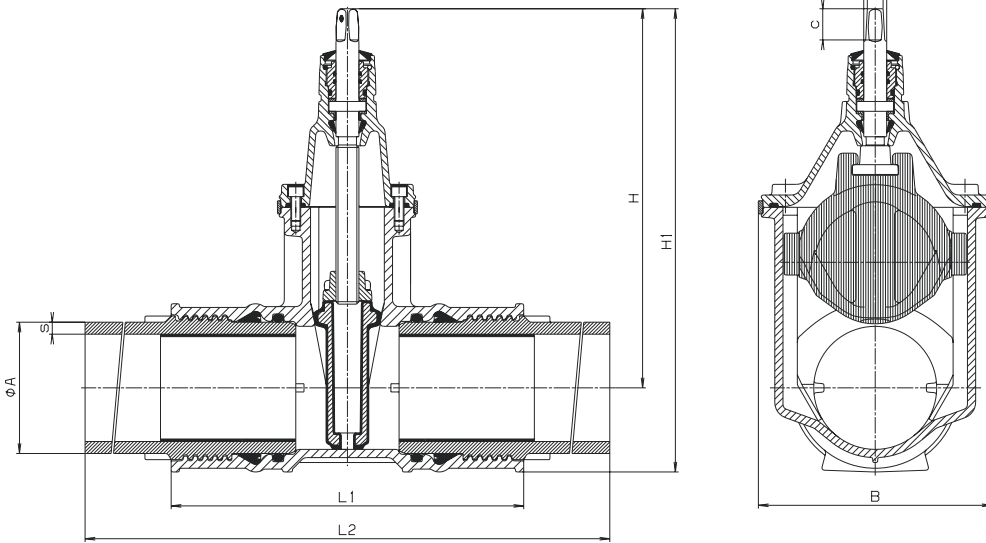

DN	Ø A	Valve with PE tails							Spindle			Weight kg
		s (PN 6)*	s (PN 10)**	H	H 1	L 1	L 2	B	a	c	d 1	
25	32	2,0	3,0	164	192	196	518	80	10,3	20	14	11,5
32	40	2,3	3,7	199	234	230	556	103	10,3	20	16	11,5
40	50	2,9	4,6	199	242	240	576	103	10,3	20	16	11,5
50	63	3,6	5,8	260	309	280	648	143	14,8	30	22	11,5
65	75	4,3	6,9	328	384	295	657	180	17,3	35	25	17,5
80	90	5,1	8,2	336	400	310	668	180	17,3	35	25	20,0
100	110	6,3	10,0	373	449	340	710	213	19,3	38	25	27,5
100	125	7,1	11,4	373	458	395	761	213	19,3	38	25	30,0
125	140	8,0	12,8	450	542	390	756	285	19,3	38	28	44,0
150	160	9,1	14,6	462	565	430	796	285	19,3	38	28	52,0
150	180	10,4	16,4	462	577	458	814	285	19,3	38	28	61,5
200	200	11,4	18,2	563	701	514	900	357	24,3	48	32	92,0
200	225	12,8	20,5	563	701	514	900	357	24,3	48	32	94,0

*SDR 17.6 **SDR 11