

Order no.	Application	PN	Dimensions/DN The valve is sized in accordance with the smaller flange													
			100 65	100 80	150 80	125 100	150 100	200 100	200 150	250 150	300 150	250 200	300 200	300 250		
4150E2	for water and non aggressive waste water other applications on request	16	●	●	●	●	●	●	●	●	●	●	●	●	●	●

Resilient seated gate valve with unequal flange sizes

of ductile iron

epoxy powder coated

This **E2 Elypso Reducing Valve** is a valve and a reducing connector in one piece. This feature offers major material and space saving benefits, particularly at junctions and branches where a reduction is needed.

The E2 Elypso Reducing Valves when used in conjunction with the Hawle cross connection fittings enable crossing points to be designed with excellent savings in the number of joints and fittings, and in labour and stock holding costs.

Material and design features:

- 1/2 **Body (1) and Bonnet (2)** of ductile iron EN-GJS-400-18 according to EN 1563 (GGG 400 - DIN 1693) inside and outside epoxy powder coated according to DIN 30677-T2 in accordance with DIN 3476 and all quality and test requirements of RAL quality mark 662 (GSK - Gütegemeinschaft Schwerer Korrosionsschutz - the association for high quality corrosion protection)
- 3 **Stainless steel spindle** St 1.4021 (X20Cr13), with rolled thread
- 4 **Wedge** of ductile iron EN-GJS-400-18 according to EN 1563 (GGG 400 - DIN 1693), inside and outside fully rubberized with vulcanized elastomer, suitable for potable water, with drain hole
- 5 **Wedge guide** of wear resistant plastic with high gliding features; optimally placed design guarantees lowest wear and tear and lowest closing torques
- 6 **Wedge nut** of dezincification resistant brass CuZn36Pb3As, generous oversizing of the required thread length in the wedge nut guarantees highest possible breaking torques
- 7 **O ring bush** of Ms 58
- 8 **O rings** of elastomer, embedded in non-corrosive material (according to DIN 3547-T1) and replaceable under pressure up to DN 200 (according to ISO 7259), for DN 250 and higher without pressure
- 9 **Back seal** of elastomer, suitable for potable water
- 10 **Circlip** of POM
- 11 **Wiper ring** of elastomer
- 12 **Bonnet gasket** of elastomer, suitable for potable water
- 13 **Allen screws** St 8.8 DIN 912 absolutely corrosion protected by being sunk into the body and sealed, and by passing through bonnet gasket
- 14 **Edge protecting ring** of PE avoids damages during transport and storage
- 15 **Friction washers** of POM guarantee smooth spindle guiding

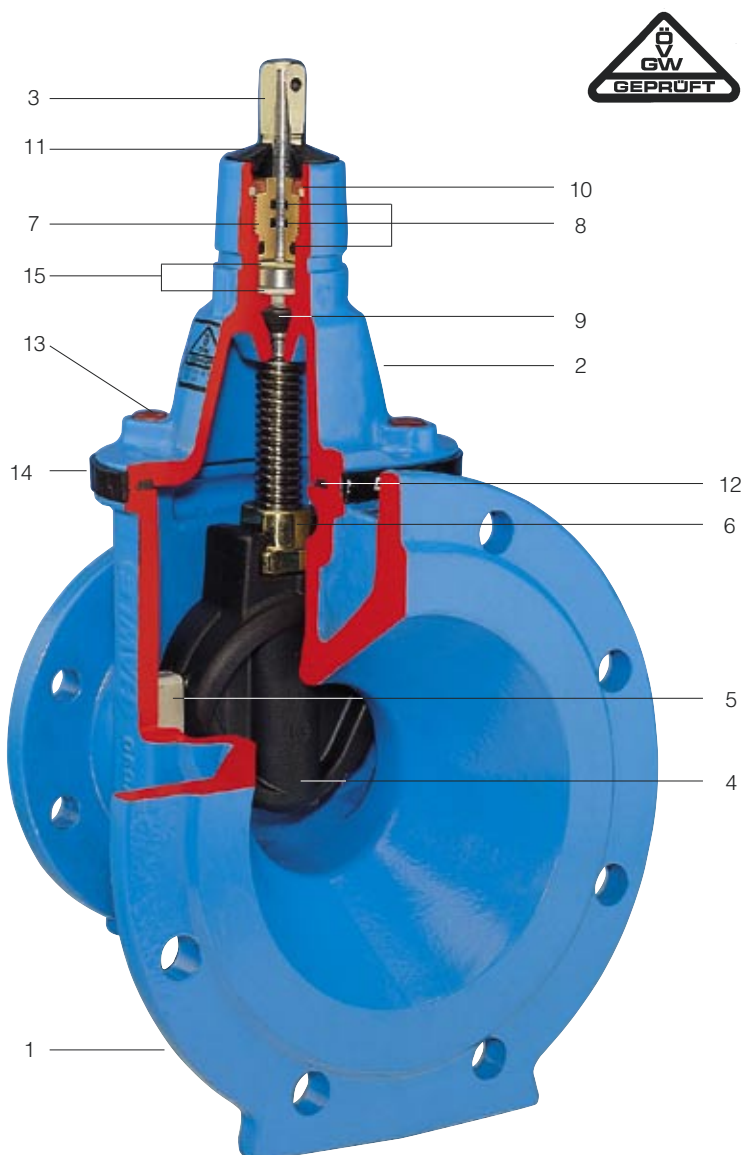

Flanges according to EN 1092-2, drilled to DIN 2501 - PN 10 (standard);

For DIN 2501 - PN 16 in sizes of DN 200 mm and above please specify on order - other standards of request !

E2 Elypso Reducing Valve

- Standard version:** without handwheel and extension spindle
- Design versions:** for electric actuator: No. 4150ELE2;
with position indicator: No. 4150STE2
- Special versions:** **on request !**
- Suitable accessories:** **Handwheel:** No. 7800
- Extension Spindles:** rigid No. 9000E2, for DN 250 and higher No. 9000
telescopic No. 9500E2, for DN 250 and higher No. 9500
- Surface Boxes:** rigid No. 1750, telescopic No.2050

Design features:

- easy retrofitting of position indicator and automatic actuator on the standard bonnet
- one extension spindle for several dimensions
- optimally placed wedge guide of wear resistant plastic guarantees lowest wear and tear and lowest closing torques, suitable for frequent operations at a differential pressure up to 16 bar
- 100 % suitable for operation by automatic actuators
- generous oversizing of the required thread length in the wedge nut guarantees highest possible strength
- O rings embedded in non-corrosive material (according to DIN 3547-T1)
- replaceable O rings
 - up to DN 200 under pressure (according ISO 7259)
 - from DN 250 without pressure

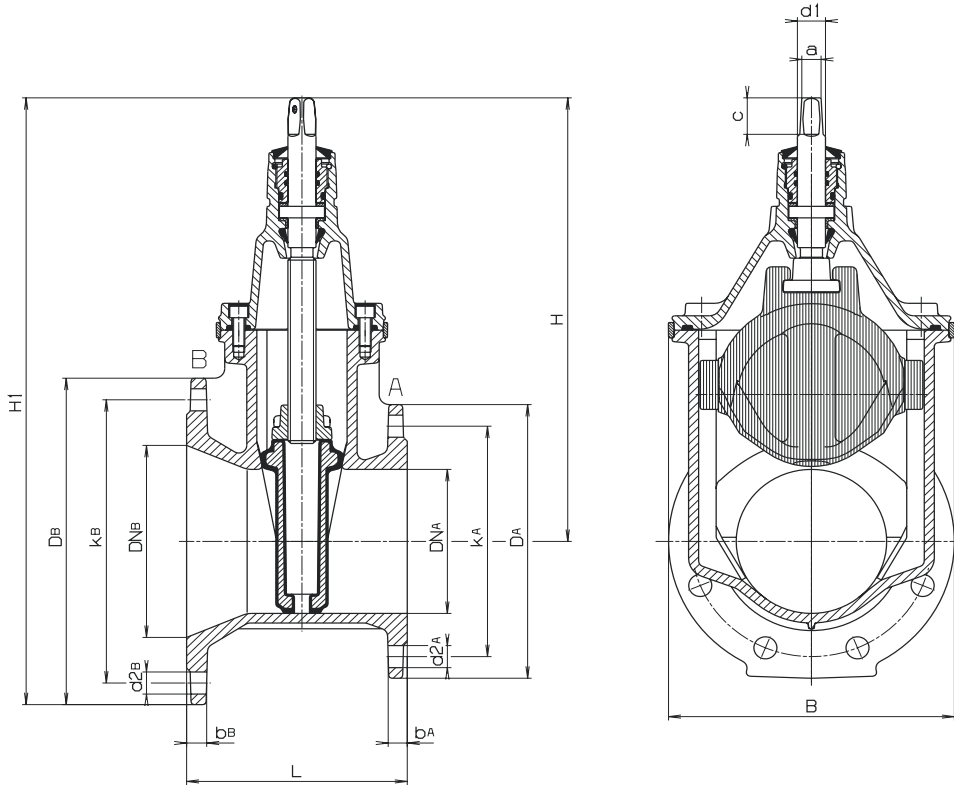

The valve is sized in accordance with the smaller flange nb*, nA* = bolts per flange

DN	PN	Flange A					Flange B					Valve				Spindle			Weight kg
		DA	ba	KA	d2A	nA*	DB	bb	KB	d2B	nb*	H	H 1	L	B	a	c	d 1	
100 - 65	10/16	185	19	145	19	4	220	19,0	180	19	8	328	438	180	180	17,3	35	25	19,0
100 - 80	10/16	200	19	160	19	8	220	19,0	180	19	8	336	446	190	180	17,3	35	25	20,0
150 - 80	10/16	200	19	160	19	8	285	19,0	240	23	8	336	479	200	180	17,3	35	25	24,0
125 - 100	10/16	220	19	180	19	8	250	19,0	210	19	8	373	498	200	213	19,3	38	25	25,5
150 - 100	10/16	220	19	180	19	8	285	19,0	240	23	8	373	516	210	213	19,3	38	25	28,0
200 - 100	10/16	220	19	180	19	8	340	20,0	295	23	8/12	373	543	210	213	19,3	38	25	32,0
200 - 150	10/16	285	19	240	23	8	340	20,0	295	23	8/12	462	632	220	285	19,3	38	28	46,5
250 - 150	10/16	285	19	240	23	8	400	22,0	350/355	23/28	12	462	662	230	285	19,3	38	28	52,5
300 - 150	10/16	285	19	240	23	8	455	24,5	400/410	23/28	12	462	690	240	285	19,3	38	28	57,0
250 - 200	10/16	340	20	295	23	8/12	400	22,0	350/355	23/28	12	563	763	240	357	24,3	48	32	68,0
300 - 200	10/16	340	20	295	23	8/12	455	24,5	400/410	23/28	12	563	791	250	357	24,3	48	32	74,0
300 - 250	10/16	400	22	350/355	23/28	12	455	24,5	400/410	23/28	12	670	898	260	432	27,3	48	34	105,0