

Assembly instructions: see page H 4/1

Connector equal No. 6365

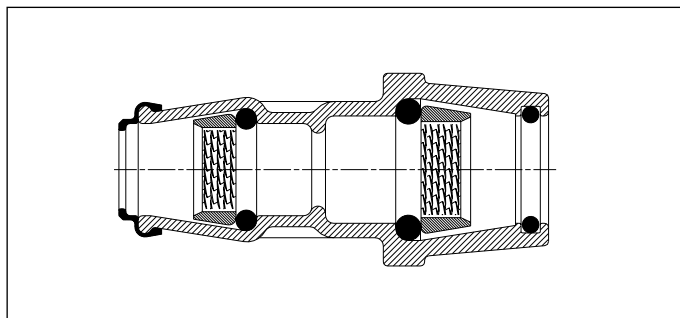

Support liner see page D 3/1

PE pipe Ø mm	PE coated pipe		Weight kg	
	Pipe Ø mm	Stripped Ø mm		
25	30,5	28,9	0,13	●
32	37,5	35,7	0,26	●
50	52	50,0	0,45	●

Connector reduced No. 6375

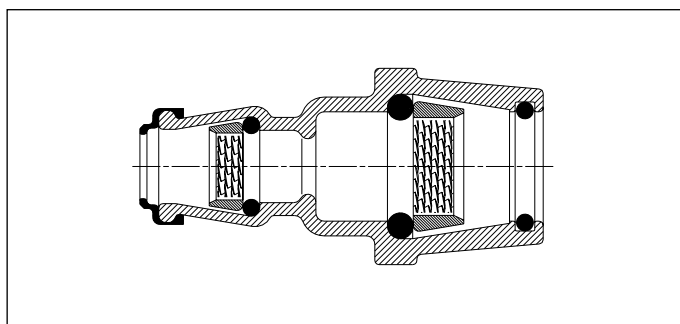

Support liner see page D 3/1

PE pipe Ø mm	PE coated pipe		Weight kg	
	Pipe Ø mm	Stripped Ø mm		
25	37,5	35,7	0,23	●
40	37,5	35,7	0,33	●

Elbow 90° equal No. 6485

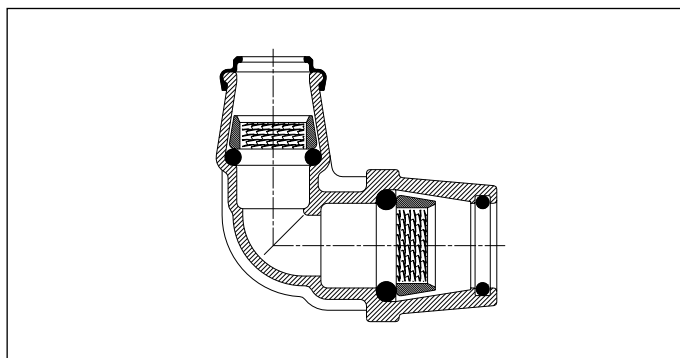

Support liner see page D 3/1

PE pipe Ø mm	PE coated pipe		Weight kg	
	Pipe Ø mm	Stripped Ø mm		
25	30,5	28,9	0,15	●
32	37,5	35,7	0,26	●
40	45,5	44,0	0,38	●
50	52	50,0	0,50	●
63	64	62,6	0,77	●

Elbow 90° reduced No. 6495

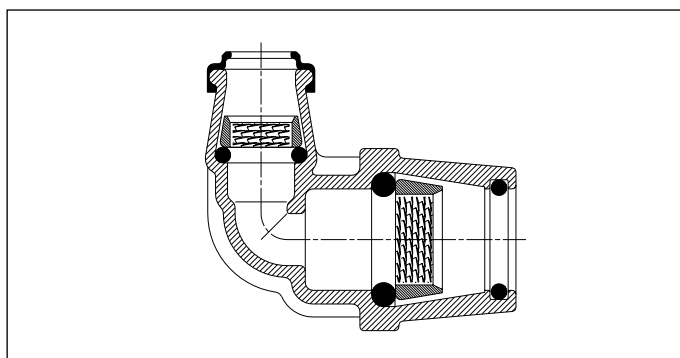

Support liner see page D 3/1

PE pipe Ø mm	PE coated pipe		Weight kg	
	Pipe Ø mm	Stripped Ø mm		
25	37,5	35,7	0,24	●
40	37,5	35,7	0,35	●

Assembly and Dismantling instructions ISO Pipe Fittings

for PE pipes

ASSEMBLY - please use always a new fitting !

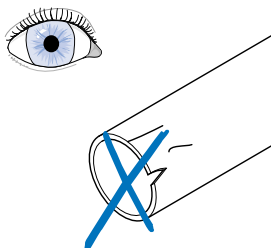
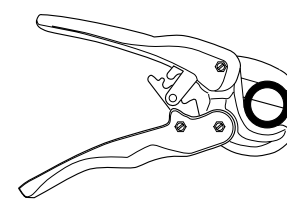
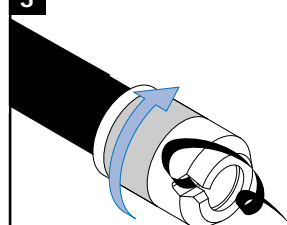
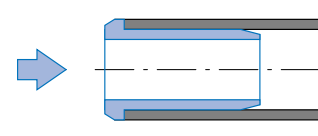
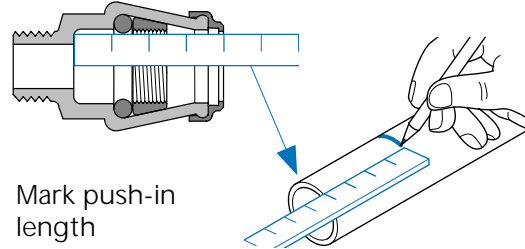
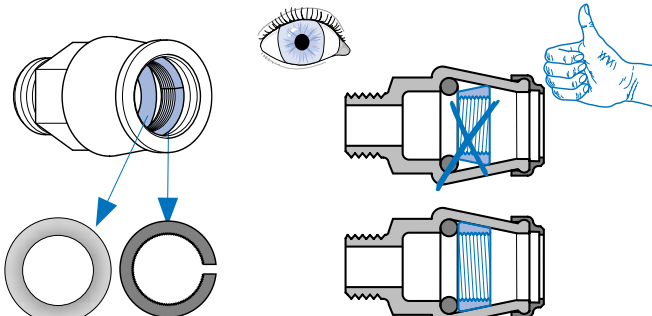
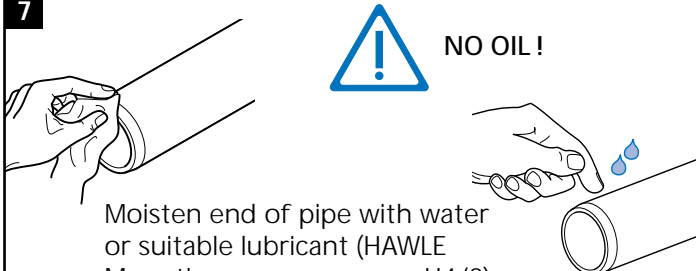
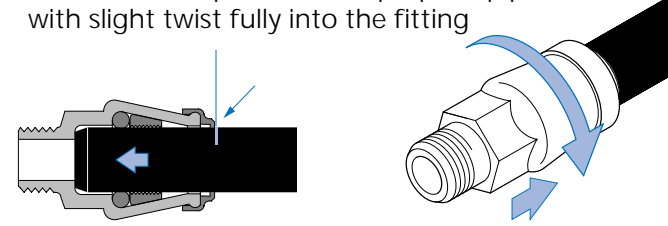
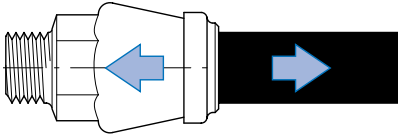
<p>1</p> 	<p>2</p>  <p>Pipe Cutter No. 6050</p>	<p>3</p>  <p>Chamfering Tool No. 6000</p>	<p>4</p>  <p>use ALWAYS a support liner !</p>
<p>5</p>  <p>Mark push-in length</p>	<p>6</p> 		
<p>7</p>  <p>Moisten end of pipe with water or suitable lubricant (HAWLE Mounting-spray see page H4/2)</p> <p>NO OIL !</p>	<p>8</p> <p>Assemble with protection cap - push pipe with slight twist fully into the fitting</p> 		
<p>9</p> 	<p>10</p> <p>Pressure tests have to be carried out before refilling the trench !</p>		

DISMANTLING

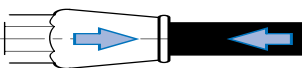
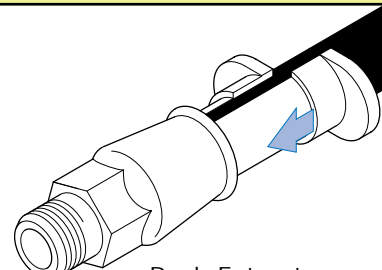
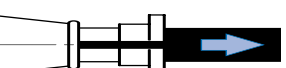
<p>1</p>  <p>Remove protection cap and release the grip (rotate fitting and push towards pipe)</p>	<p>2</p>  <p>Push Extractors No. 6010 fully home</p>	<p>3</p>  <p>Withdraw the pipe with slight twist</p>
--	--	--