

for GAS according to EN 437



REG. NR. G 1.475

The prescribed pressure test for gas valves will be attested by certificate in accordance with DIN 50049 (EN 10204) - 3.1.B.

Order no.	Face-to-face dimension	PN	Dimensions/DN						
			50	65	80	100	125	150	200
4005E2	short (DIN 3202 F 4) EN 558-1 GR 14	16	●	●	●	●	●	●	●
4705E2	long (DIN 3202 F 5) EN 558-1 GR 15	16	●	●	●	●	●	●	●

Resilient seated gate valve with smooth straight-through bore

Material and design features:

- 1/2 **Body (1) and bonnet (2)** of ductile iron EN-GJS-400-18 according to EN 1563 (GGG 400 - DIN 1693) inside and outside epoxy powder coated according to DIN 30677-T2 in accordance with DIN 3476 and all quality and test requirements of RAL quality mark 662 (GSK - Gütegemeinschaft Schwerer Korrosionsschutz - the association for high quality corrosion protection)
- 3 **Stainless steel spindle** St 1.4021, with rolled thread
- 4 **Wedge** of ductile iron EN-GJS-400-18 according to EN 1563 (GGG 400 - DIN 1693), inside and outside fully rubberized with vulcanized elastomer - DIN 3535, with drain hole
- 5 **Wedge guide** of wear resistant plastic with high gliding features; optimally placed design guarantees lowest wear and tear and lowest closing torques
- 6 **Wedge nut** of dezincification resistant brass CuZn36Pb3As, generous oversizing of the required thread length in the wedge nut according to prEN 1171 guarantees highest possible breaking torques
- 7 **O ring bush** of Ms 58
- 8 **O rings** of elastomer - DIN 3535, embedded in non-corrosive material (according to DIN 3547-T1) and replaceable under pressure (according to ISO 7259)
- 9 **Back seal** of elastomer - DIN 3535
- 10 **Circlip** of POM
- 11 **Wiper ring** of elastomer
- 12 **Bonnet gasket** of elastomer - DIN 3535
- 13 **Allen screws** St 8.8 DIN 912 absolutely corrosion protected by being sunk into the body and sealed, and by passing through bonnet gasket
- 14 **Edge protecting ring** of PE avoids damages during transport and storage
- 15 **Friction washers** of POM guarantee smooth spindle guiding

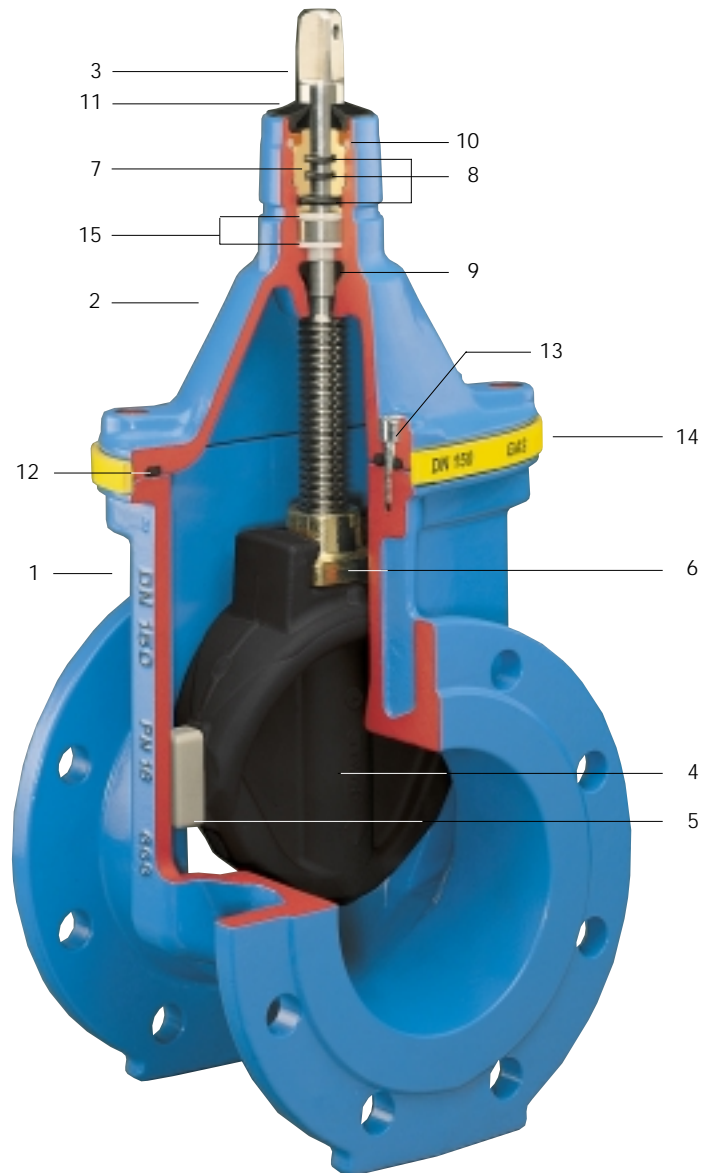

Flanges according to EN 1092-2 (DIN 28605), drilled to DIN 2501-PN10 (standard); for DIN 2501-PN 16 in size of DN 200 mm please specify on order - other standards on request !

E2 Valve Flanged Ends DN 50-200

Standard version: without handwheel and extension spindle

Suitable accessories: **Handwheel:**
No. 7800

Design versions: for electric actuator: No. 4005ELE2;
with position indicator: No. 4005STE2

Extension Spindles:
rigid No. 9000E2
telescopic No. 9500E2

Special versions: on request

Surface Boxes:
rigid No. 1755, telescopic No. 2055

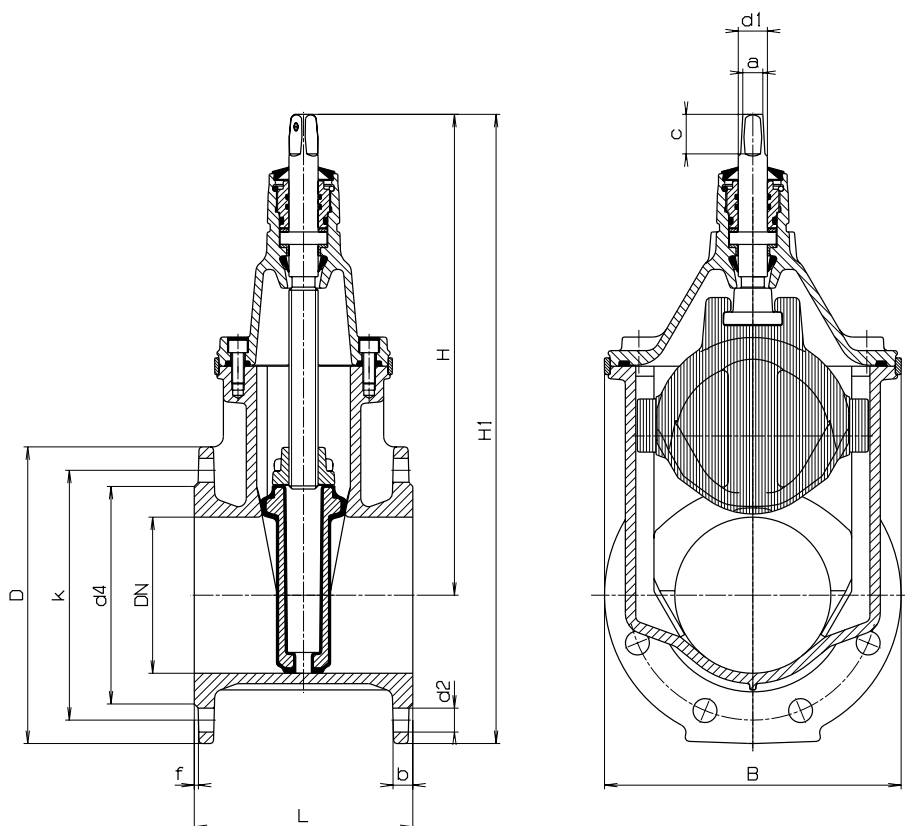

Design features:

- easiest retrofitting of position indicator and automatic actuator on the standard bonnet possible
- one extension spindle for several dimensions
- optimally placed wedge guide of wear resistant plastic guarantees lowest wear and tear and lowest closing torques, suitable for frequent operations at a differential pressure up to 16 bar
- 100 % suitable for operation by automatic actuators
- generous oversizing of the required thread length in the wedge nut according to prEN 1171 guarantees highest possible breaking torques
- O rings embedded in non-corrosive material (according to DIN 3547-T1)
- replaceable O rings under pressure (according to ISO 7259)

DN	PN	Flange					Bolts			Spindle			Valve					Weight kg	
		D	b	k	d 4	f	Qty.	Thread	d 2	a	c	d 1	H	H 1	L short	L long	B	short	long
50	$\frac{10}{16}$	165	19	125	98	3	4	M 16	19	14,8	30	22	260	342	150	250	143	11,0	12,0
65	$\frac{10}{16}$	185	19	145	118	3	4	M 16	19	17,3	35	25	328	420	170	270	180	17,0	18,5
80	$\frac{10}{16}$	200	19	160	133	3	8	M 16	19	17,3	35	25	336	436	180	280	180	18,5	20,5
100	$\frac{10}{16}$	220	19	180	153	3	8	M 16	19	19,3	38	25	373	483	190	300	213	24,5	27,5
125	$\frac{10}{16}$	250	19	210	183	3	8	M 16	19	19,3	38	28	450	575	200	325	285	35,0	38,0
150	$\frac{10}{16}$	285	19	240	209	3	8	M 20	23	19,3	38	28	462	605	210	350	285	40,5	46,0
200	$\frac{10}{16}$	340	20	295	264	3	$\frac{8}{12}$	M 20	23	24,3	48	32	563	733	230	400	357	64,0	72,0

Illustrations, technical data, dimensions and weights are subject to alteration without notice.

1. 2001